

الجمهورية الجزائرية الديمقراطية الشعبية
وزارة التعليم العالي والبحث العلمي

جامعة الجزائر
معهد الآثار

رسالة لنيل درجة الماجستير
في الآثار الإسلامية
بموضوعات:

قصر بوسمغون بولاية البيض دراسة أثرية تحليلية

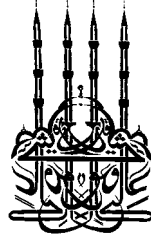

تحت إشراف الدكتور:
علي حملاوي

إعداد الطالبة
نحمون منى

السنة الجامعية
2005/2004



بِسْمِ اللَّهِ الرَّحْمَنِ الرَّحِيمِ

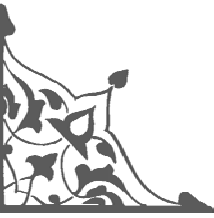



المقدمة

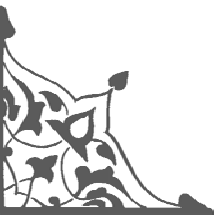

1 -1

.

·
" "

.

" "

.

.

" "

)

" " " "

(

" "

“ ”

“ ”

“ ”

“ ”

“ ”

“ ” 11/

13/

“ ” 14/

17 /

“ ” 10/

“ ” 13 /

“ ” 14/

“ ” 15 /

“ ”

"	"				
		(Colomieu) "	"	1853 (Duveyrier) "	" (Colomb)
1868	"	"	"	() "	" 1862
				"	" () "
				"	"
	"	"		1845 (Daumas) "	"
"	"	"		(L.Leclerc) "	"
	"	"		1858 "	"
			"	"	
"			"	"	1878
			"	"	"
"	"	19	"	"	"
				1957 "	"
				(René Basset) "	"
			1885		1885
			"	"	

	1894	"	"	(Kiva)	"
"		"	"	(Mathéa Gaudry)	"
					1933
"				(Geay)	" "
			1935	"	"
				"	" "
			"		
1936	(André Basset)	"	"		"
	(Jean Vialatte De Penille)	"	"		"
	"				
					1949
	"	"			

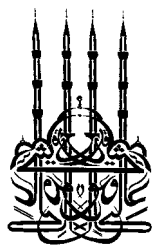



الفصل الأول

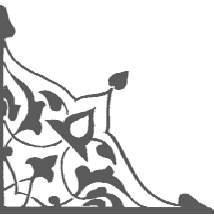

دراسة عامة
مفهوم القصر ، اللوحة الجغرافية والتاريخية

-I :

- II :

1

2

3

4

5

-

-

-

III -اللمحة التاريخية

-1

-2

-

IV- التنظيم الاجتماعي

1

2

() 3

4

5

6

7

2« ... »

1

3 « ... »

4

“ ” “ ”

5

6

...

.186 1993

11

() -1

10. -2

73. -3

633. 1986 21 -4

Despois (j) , le djbel amour , presses universitaires de france paris , 1957 , p 25 - -5

Colomieu , voyage dans le sahara algerien de géryville à ouargla , le Tour du Monde , 1863 , p 162 -6

: II

: 1

1

3 " " 2 160

(1) .4

-1

" "

" :

1845

" "

"Lignyville" "

" " :

1852

1320

280

Roger Duvollet, d'Alger à Tamanrasset , tome3, 1983, p62

2006

Roger Duvollet, villages d'Algérie et oasis du Sahara , tome7, 1987,p12

Raymond Couderc, les hautes steppes sud -oranaïses ,university paul valery Montpellier,SD

1974

-2

4

()

" "

" "

" "

Daumas (l.c.)le Sahara algérien études géographiques, :

statistiques et historiques sur la région au sud des établissements français en Algérie, paris ,Alger 1845, p221,222

Geay(M), Le médecin capitaine., études médicales de l'annexe de Geryville 1 mars 1935 p77,78

Cominardi (F) , Au coeur des monts des ksour le ksar de Chellala Dahrania , juin 1994

Accardo(F), Répertoire alphabétique des tribus et d'Uares de l'Algérie ,Alger 1879, p50

726

225

-3

Duvyrier (H) , Historique Exploration au sud –ouest de Géryville , Alger , SD .

60 50

» " "

-4

Daumas (L C) , Opcit, P245

« ...

" " 33° 32°
 " " 1148
 . 2 584.82 1932 " " 1989
 1994 1 1407 1936
 . 3520
 : _____ 2

" " " " " " " :
 (2) " " " " " " "

	160	()	
	160	()	
	45		2
	110	()	3
	90	()	4

Gouvernement Général De L'Algérie, répertoire statistique des communes de -1
l'Algérie, territoires du sud, décembre 1936, Ancienne Impr. Victor Heintz, 41 rue Mogador, Alger,
 1937,p230,231
 1845 " " -2
 .Accardo (F),opcit, P74 Daumas (L.C) , Opcit, P 220
 -3
 _____ () " "
 . 14 1977 2 2
 " " (La jolie terre) () -4

Campillo (capitaine), Le tourisme dans le cercle de Ain-Sefra, ou un itinéraire touristique
 d'Alger à Ain-Sefra, Impr. Rives, Romeu, SD, P 12 ,13
 Leon Lehuraux, Le Sahara ses oasis ,Alger ,05 mais 1934, P 156,157,158 .

" "

	80		1
	30		2
	60	()	3

" " " "

:

" " " " " "

" " " "

4" " " "

.(1) . 2 1

5 " " " " 20

(1) 6

. 7

. 2 800 -1

40 30 » -2

Daumas(L.C) ,opcit, p219 «....

«.... 40 30 » -3

Daumas(L.C) ,opcit, p218

.

Vialatte (Jean) De Penille , Bousemghoun " Ksar Berbere Des Monts Des Ksour Et Son Oasis, -4
 1949,P12

. 20 -5

.Geay (M) ,Opcit, P77 -6

Mathea Gaudry , La Societe Feminine Au Djebel Amour Et Au Ksel ,Alger, 1961, P61 -7

: -3

" "

1" " " "

2109 " " 2130 " 2 " :

2020 " "

" " 2000 "3

4" " " "

-1

123. 1965 30

-2

2130 1800

Battondier Trabut 1888

Rene Maire , La végétation des montagnes du sud oranais , Alger , 1916 , p 63

Cornet (A) , Monographies régionales, L'atlas saharien sud oranais , Alger , 1952 , P 5 -3

" " " " -4

" "

" " 1272 " " 1989
 " " " "
¹ 1424 " "
 2
³ 994
 (3).
 : 4

" 7 " "6 " "5 " "4 " :

Augustin Bernard, Atlas d'Algérie et de la Tunisie , Algérie, SD -1
 -2
 Plan directeur d'aménagement et d'urbanisme de la commune de Bousseghoun,rapport -3
d'orientations et règlement, B.E.P Cité Nasr , Elbayadh,1994 . -4
 Trumelet, L'histoire de l'insurrection dans le sud de la province d'Alger, Rev.Afr,N°146,
 1888,p84,85
 100 -5
 Trumelet,opcit , p84,85 .
 Cornet (A) ,opcit, p6 " " " " -6
Opid,p6 -7

" " : " "

" " " " " "

. ()

. .

8 " " " "

1

5

². ()

Mathea Gaudry ,Opcit, p 62 -1

Geay (M) ,Opcit, P77 - -2

-

1935

°8

" "

°41

.1

" "

°23

20.4	9.5	3.85	1.8-	15-
23.3	11.3	5.30	0.7-	10.4-
25.8	14.6	8.40	2.2	6.9-
28.1	19.1	11.90	4.7	4.5-
32.1	22.9	15.65	8.4	0.2-
36.4	29.6	21.50	13.4	5
38.9	33.5	25.15	16.3	7.2
38.8	33.3	25.05	16.8	6.8
35.5	28	20.55	13.1	1.8-
31.1	21	14.45	7.9	1.8-
24.6	13.5	8	2.5	5.9-
20.6	9.7	4.5	0.7-	9.1-

P.Seltwer,1946

200

-

" " 1949 13 - " " " "

1

" " " "

9	30	
8	25	
8	34	
6	27	
6	28	
5	19	
4	6	
5	9	
6	37	
6	32	
3	41	
8	38	
80	32	

P.Seltwer,1946

9	12	7	9	5	5	6	15	14	11	9	10	9	
13	10	11	14	13	11	14	18	17	13	13	10	13	
11	11	11	12	14	11	12	10	9	9	9	10	12	
19	13	15	19	27	27	26	25	19	14	15	14	15	
17	15	16	20	21	27	21	15	14	17	16	15	12	
12	16	17	13	11	12	9	7	8	10	13	16	12	
7	9	9	5	3	3	5	3	4	8	9	9	11	
12	14	14	8	6	4	7	10	15	18	16	16	16	
12	13	11	10	9	12	10	12	13	11	12	15	13	
5	5	4	6	4	6	4	5	4	4	4	5	8	
2	2	2	2	3	2	1	2	2	1	2	2	3	
11	5	9	11	15	15	14	10	12	10	9	8	6	
16	11	13	18	25	25	22	20	16	15	14	11	8	
18	19	20	18	17	18	19	15	16	19	17	16	18	
13	16	16	14	10	8	10	9	13	13	16	15	15	
23	29	25	21	17	14	20	21	24	27	26	28	29	
17	15	14	15	17	17	18	20	20	18	17	17	16	
7	6	6	7	8	9	9	9	7	5	5	6	7	
2	2	2	3	3	3	2	2	1	2	1	2	4	
10	5	8	11	15	11	14	14	9	8	9	6	6	
15	14	14	16	19	19	17	14	14	14	13	12	11	
13	16	15	15	12	14	11	11	12	13	13	14	15	
11	14	15	10	6	8	8	7	8	11	15	14	13	
25	28	26	23	20	19	21	23	29	29	27	29	28	

13

13

18

(Seltzer) :

1 .

" " " "

200

" "

" " " "

" 2 " "

3 " "

Henri Lhote ,Les Gravures Rupestre Du Sud Oranais ,Arts Et Metiers Graphiques ,18
Rue Segulier ,Paris 6,1970

. 1881 " " " " : -2

Iliou Et G.Lefelver ,Cinq Stations De Gravures Rupestres De La Region De Bou-Semghoun -3
(Monts des Ksours) ,Lybika ,Alger , tome 20, 1972 , p 179 ...p185

" " " "

" "

" " " "

" "

1

1858 " "

" "

. 2 " "

" "

3 .

. (2) _____ -1

Leclerc (L), Les Oasis De La Province D'Oran Ou Ouled Sidi Cheikh, Tissier libraire -2
éditeur , rue Bab El-Oued ,Alger, 1858,p62

- Kiva , En Algerie (Souvenirs) , Editeur Militaire ,Henri Charles ,Lavauzelle , 11 Place Saint -3
André Des Arts , Paris , 1894 ,P49

1758/ 1171 " " " " " "

"

" " " " " " " " " " " "

" " " " " "

" " " " " "

1768/ 1181 " "

" " 1773/ 1186 " " " "

2" " :

3" " " "

1784/ 1196 " " " " " "

45

5

Arnaud (L),Opcit , p 469 -1

1 -2

. 5 2002

2 1 -3

518. 1985 -4

. 518

.6 -5

" " .

" " " "

.1

1798/ 1213 " "

" "

" " " "

" "

2

" "

1815 19

1230

.4

" "

3

6

5

.6 _____ -1

.8 _____ -2

Demaeght (L) , Document Arabe, texte arabe et traduction française d'une lettre écrite -3
par Hasen 33^{eme} et dernier Bey d'Oran à Ali Caid de Melliana, B.S.G.O, 1893 , p 151.

. 57 _____ -4

. 58 _____ -5

: : -6

93 1960

. 178 177

2 _____ ()

ص

"

(100) "

" (50)

(30) "

.¹

.²

25 1890

3

4

.

195 1995

. 139

.195

-1

. 1996

-2

: -3

-4

" " " " " "

2

1

3

البربرية " "

" "

" "

" "

:

: 1

: 2

André Basset, Situation Actuelle De Parlers Berberes Dans Le Departement D'Oran, -1

Rev Afr, N° 368,369, 1936, p1000,...,1006.

Leclerc (L), Opcit, p 69. -2

) " " " "

(

Réné Basset ,Nates De Lexicographie Berberes , Dialecte Des Kçours Oranais Et De .

Figuig , J. A., Tome 6, Juillet 1885, p302,...,p371.

. 1858

Réné Basset ,Dialectes Du Sud Oranais Et De Figuig Dialecte De Boussemr'oun,B.C.A.,

Tome 3, Imprimerie De L'association Ouvrieres,Fontana Et C^{ie} , Alger, 1885,p389,...,p427

Gay (M) ,Opcit, P 7 -3

:() 3

: 4

: 5

: 6

: 7

...

... 2

1

)

Leclerc (L), Opcit, p 63.

Geay (M) ,Opcit, P 77

- 1

- 2



الفصل الثاني

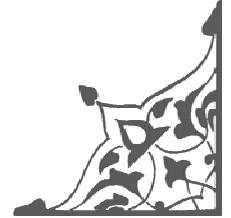
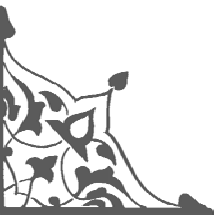

المنشآت الدينية

-I

-1

-2

-3

-4

-5

-6

-II

I- المسجد الجامع:

1

:

ص²

" "

3

4 28

" " " "

» :

⁵ «

»

. ⁶«

. 175 6 _____ - 1

1970

- 2

.55

65. - 3

.140 1988

1 _____ - 4

. 31 _____ - 5

. 108 _____ - 6

(2)

1

1902

1952

1927

1

... »

2

. 4 «

....»

3«

ص

. 5

12

1.10

1

2.77

(9)

.

_____ -1

. 195 194

.11 1999 2

_____ -2

. 37 .-3

. 39 -4

.325 2000

1 _____ -5

1

2

3

ص

4

—

«

»

—

5

726

6

0.62

0.70

0.75

2.58

(9)

			. 27	-1
			. 491	-2
.78	1998		1	-3
251.	1960		1	-4
	2			-5
			247.	
.100	99	1992		-6

: -4

1

)

(10

2

: -5

(11) 11.90 × 17

121 2000

-1

.122

Commandant Cauvet , Les Marabouts , Rev. Afr. , 1923 , N° 64 P294 P307

-2

2

3
" " " " " "
" " " " " "
4
" " " " " "
6"

ص »

«

7

27

«

»

-1

310.

101.

- 2

-3

.3

. 34 1913

-4

21

-5

.14

-6

.111 1946

-7

(2)

21 2.80

.
" "

. (12) 0.20

2.75 1.20

. " " 1

0.60 × 1.74

0.60

0.40

9 34

0.28

(1)

.) -

" " " "

1

ص².

. 7 1892

. 362	_____	-1
1	_____	-2

. 1

» :

. 2 «

" "

. 3 «

... »

. 4

" 5

6 "

. 7

116 1

_____ -1

. 363 _____ -2

. 37 _____ -3

. 84 _____ -4

. _____ -5

.5239 17 _____ -6

.19 1974 6 _____ -7

»

.¹ «

.²

»

.³ «

» " "

" 1379 / 781

" "

.⁴

_____ .92 _____ -1

.5240 _____ -2

Daumas (M) , La Grande Kabylie ,Etudes Historique , Alger , 1847 , P 60 -3

-4

_____ . 411 1981

. 414 _____ :

Marçais (G) , L'art Musulman , Presses Universitaires De France , Paris , 1981 , P7

.1

- -

. 2

»

" "

"

"

3«

" " "

6 4 " "

. 5 "

" " -1

»... "

.462 1998 1 «...

: :

. 147

42 41

...

. 51 1998

: :

: :

563

"

59 ... 53 1966 1

465 "

. 1957

. 17 -2

. 413 -3

.33 -4

. 33 -5

. 1
 " " :
 " " 2 " " " " " "
 " "
 3" " " " "
 " " " "
 " " "
 . 4 " "
 " "
 . 5 " "
 " "
 7" " 1215 6

		. 66		-1
			. 66	-2
		" " "		-3
			. 2000	
		. 67		-4
			. 68	-5
		. 67		-6
				-7
	. 122	1988		

.
 " " .
 (3)
 " "
 2
 (13)
 1 0.96 × 1.90
 3 . 20
 11 1.60 .
 " "
 2.86 × 5.50 4.32 × 3.06
 2.86 × 4.40
 . (14)
 6.50 × 8.70 (15)

4 3 8 6

0.90× 1.80

5 × 11

2.35

0.75

0.84

(16)

. 0.70

0.30

(13)

)

4.80 × 6.50

(17

0.85 × 1.80

1.05× 1.70

(18)

1984

)

.(...



الفصل الثالث

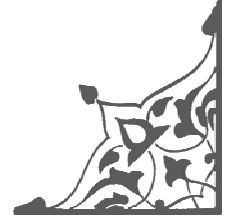
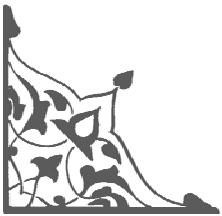

:

-I

-1

-1

. -2

. -3

. -4

. -5

. -6

. -7

-8

. -9

. -10

. -11

-2 نماذج من المنازل

(1) -1

.(2) -2

.(3) -3

.(4) -4

.(5) -5

-II

-1

. -2

. -3

. -

. -

. -

-4

:

:

-I

(4

)

أ-المنازل:

1 0.60

0.80 0.50

)² 60 ² 400

0.50 0.45

.(2

-2

.
3.80× 2

:() -3

1 :
. 2

.
" "

.

18 1962

9

. 55

-1

-2

. 1

1

2

1.5

2.80

2

.

. (24) (6)

.

0.40

(25)

.

(7)

.

ب- دراسة نماذج من المنازل:

" "

" " " " " " " "

" " " " " "

() : (1) -1

" "

² 400

" "

1.70 1

² 188

1 × 0.70

.(5).

() : (2) -2

10× 12

0.90

1.70

2.80× 2

1.20× 0.70

2.70× 4

0.40

.

2.80× 5

1.50× 2.60

.

2× 3.60

.

7× 3

3× 2.60

.(6) .

² 70

(L)

0.90× 1.70

3× 2.80

3× 2.80

0.70× 1.30

.(7) .

: (4) -4

² 100

1.60

0.80

1.10 × 0.70

0.50

2.70 × 0.50

2.50 × 3

3.50 × 4.20

1.50 × 2

2.80 × 3

6.50 × 3.80

.(8) .

0.80 × 0.60

: (5) -5

² 170

0.90 1.65

2

.

0.40

2.80 × 3

2.80 × 3.50

.

0.70

. 2.50 × 3

1

.

1.50 × 2

.

.

). .

.(9

1

.²

" "

(27) (26) 9 8

2-الأبراج:

:

:

.⁴

: .³

⁵ «

...»

6

)

.⁷(

84:85 1992

. 87 1960

. 178

1 _____ -1

_____ () -2

. 360 359 1 _____ -3

1 _____ () -4

.78 _____ -5

.34 _____ -2 -6

.176 1 _____ -7

600 500

) 7 2.60× 2.60

(28

1.30× 1.80

(29)

0.20× 0.30

3- المدخل:

1.

2.

3.

:-

" "

(30)

11 1 1 -1
39 -2
316 -3

)

: -

" " " "

.(31

: -

" "

(32)
" "

:

2.24	3.35		
2.40	2.38		
1.78	2.80		

4-الخدق:

) 1 : :

(

. 2

3

" " " " " " 4" " " " "

1.30

1.10

. 228	1993	2	4	_____	-1
	. 101			_____	.-2
. 173	1990	3	2	_____	-3
	.173			_____	-4



الفصل الرابع

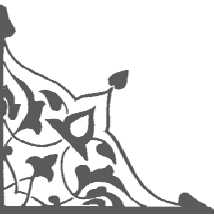

-I

-1

.()

-2

.()

-3

-4

-II

1

2

3

4

5

6

7

1

2

3

4

5

: - I
: -1

1

: -

: (10) (33)
. 110 " " - -
. 60 " " -
. " " -
. 3.50 2.80

83 -1

:() -

1

(35) (34) :

. 30 " " -

. 40 " " -

. 35 " " -

. 30 " " -

. " " -

. 15 1" " -

. " " -

0.50

30

)

.(36

)

.(11

" " " "

" "

 -1

" "

" "

-2

(37)

. (38)

1

:

. (12) :

		²		
	41	4400		1
	24	3000		2
	21	12000		3
	08	5700		4
	27	3000		5
	24	3800		6
	15	2100		7

3-الساحات (الجماعة):

1

" "

·
" " 2 270

(39

2

·
...
) (13)
.(

·
" "

		. 85	-1
1	1954	1931	-2
			. 31 1994

: -4

1

2

(40) " "

.

4 3 2.60 2

.....

" " " "

.

.

.

" "

.

-1

:

. 245

.....

. 155 -2

: - II

: -

: **1**

.(4)
" "

1.80 1.70

1.40

. 1.90 1.80 1 0.85

(8) .

2

:

1 .

2 .

ص

3 .

4 .

»

5« .

41 ----- -1

. 238 1985 ----- -2

. 34 1966 ----- -3

Bourouiba (R), Apports De L'Algérie Architecture Religieuses Arabo Islamique , O.P.U , -4
Alger , 1987, P 73 .

. 407 177 ----- -5

" "

0.50× 0.50 0.50× 0.60

.

.

⋮

1

.

2 " "

. 0.70× 0.70

.

. 1.20 0.70

(9)

. 405	_____	-1
	_____	-2

.2 1949

0.30
(41) .

:-

1

2

3 " " " "

4

- 88

⁵ 714- 707 / 96

" "

" "

).

6

(42

310. 1992 2 9 _____ -1

.332 _____ -2

. 101 1981 _____ -3

. 120 1961 _____ -4

20. 2 _____ -5

-6

()

_____ .489 1968

" "

" "

°47-° 45

(44)

.

0.90 0.80

" "

.

(11)

)

1

(L)

(11

°90

(L)

(12)

(12)

.(45)

.

7

1

" "

2

3

0.60× 0.40 0.25× 0.40

.(46)

0.60× 0.60

.(13)

1982. 3

	()	-1
20.		-2
. 65 1		-3

1

.

"

"

.

.

:

:

. 389

388

-1

1
:

1
...

2

" " :
3 « ... (" ") ... »

4 1

. (47)

% 78(SiO₂) % 0.1 (CAO)

5

(SiO₂)

6 %53.3 % 46.7

. 125 _____ -1

. 73 _____ -2

. 48 1995 2 3 _____ -3

Vialatte (J) , Opcit , P 31 _____ -4

1977 _____ -5

17

157 1984 _____ -6

: 2

. 1 :
2

3

15

. 62 1974 . 243 _____ -1
_____ -2
1 2
. 265 _____ -3

2

:

:

1

: 3
:

.³

. 0.15 × 1 × 0.25

. (14)

" "

.

. 215	1988	<hr/>	-1
	. 51	2 <hr/>	-2
	. 184	<hr/>	-3

: 4

1

.²

SIO₂

: 5

.³ «...»

...»

		<u>. 511</u>	<u>1</u>	<u>_____</u>	<u>-1</u>
4	1	<u>_____</u>			<u>-2</u>
		. 3	1994		
		. 390	<u>_____</u>		<u>-3</u>

\cdot^1
 6
)
 : (15
 $\underline{\quad\quad\quad}$

3 2
 " " ()
 .(48)
 $\underline{\quad\quad\quad}$

\cdot^2
 $\underline{\quad\quad\quad}$
 . 390 $\underline{\quad\quad\quad}$ -1
 . 119 $\underline{\quad\quad\quad}$ -2

∴ _____ -

. (15 _____)

∴ _____ -

« _____ »

∴ _____ -

∴ _____ ∴

1

∴

2

.

³«

»

. (8 _____)

“ ”

128.	1992	2	9	_____	-1
			. 103	2	_____
.374	1993	2	4	_____	-3



الخلاصة

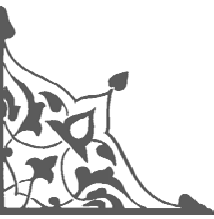

-

" "

.

" "

.

.

.

.

.

“ ”

.

.

.

.

“ ”

“ ”

.



الملاحق

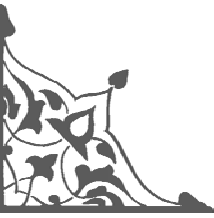

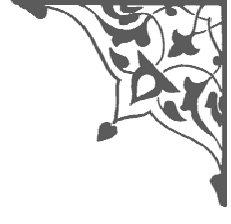

ملحق الأشكال

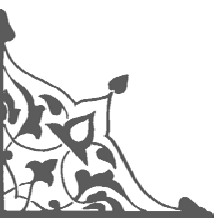

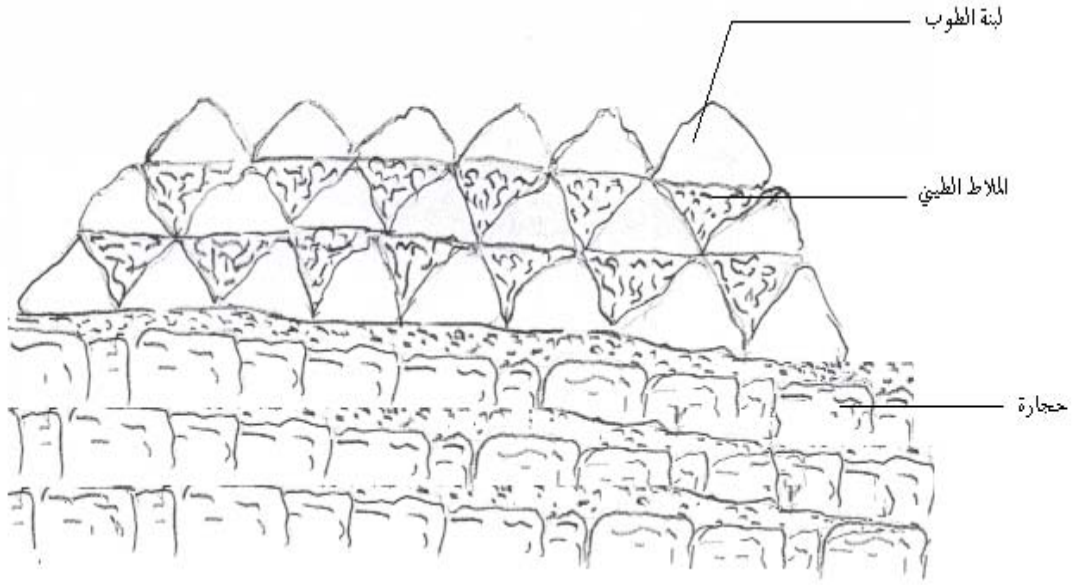

رسم تخيلي يوضح طريقة وضع الحجارة و قوالب الطوب

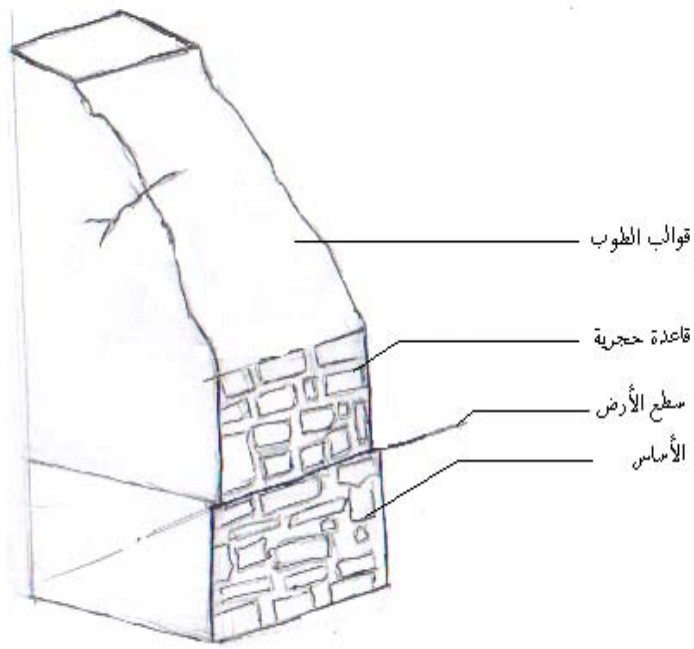

الشكل رقم (2)
يوضح قاعدة جدار المنازل
(عن الطالب)

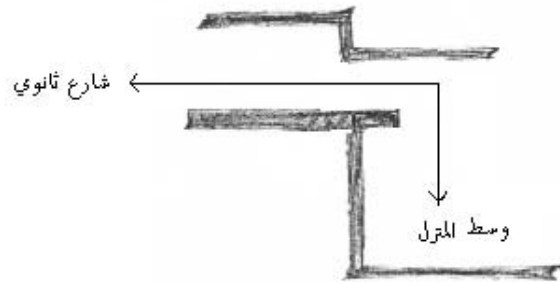
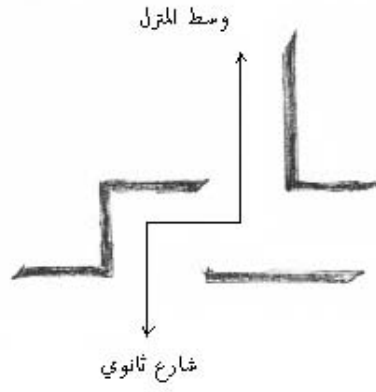
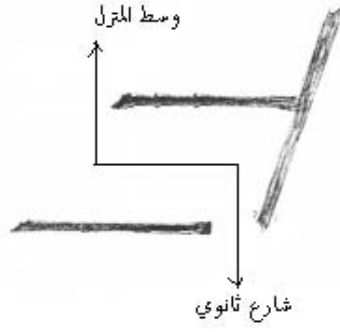

الشكل رقم (3)
يمثل نماذج من المداخل الحاجة لبعض المنازل
(عن الطالب)

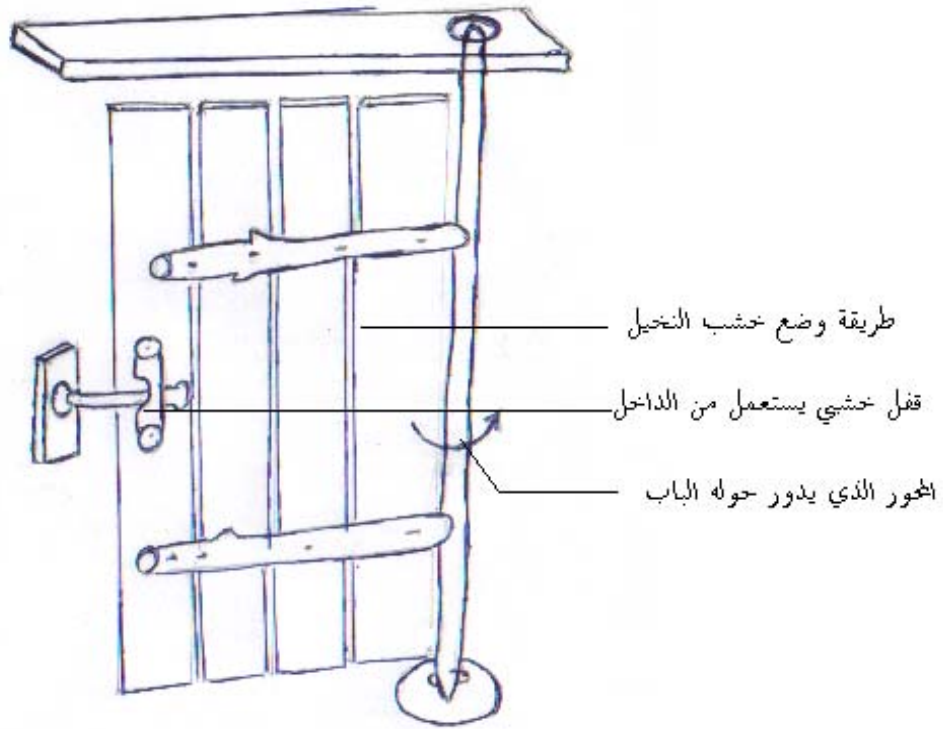
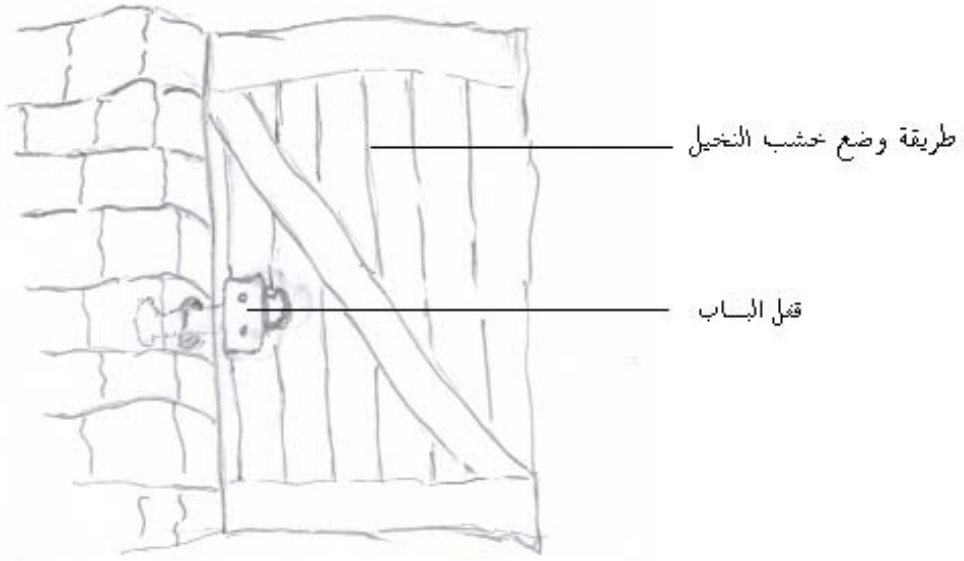

الشكل رقم (4)
 يمثل طريقة صناعة أبواب المساكن
 (عن الطاب)

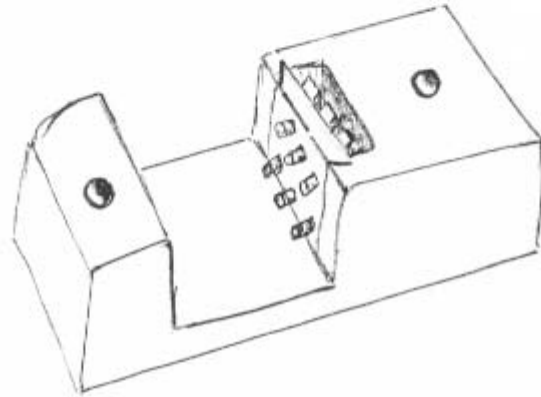
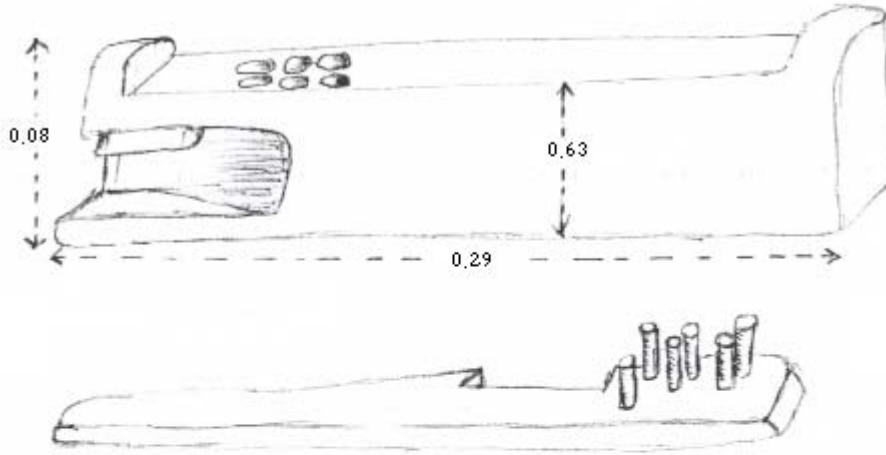

قفل خشبي يستعمل من الخارج

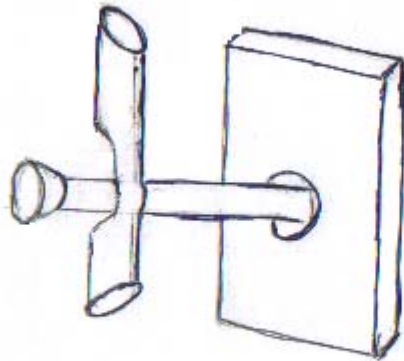

قفل باب يستعمل من الداخل

الشكل رقم (5)
يمثل القفل الخشبي لأبواب المنازل
(عن الطالب)

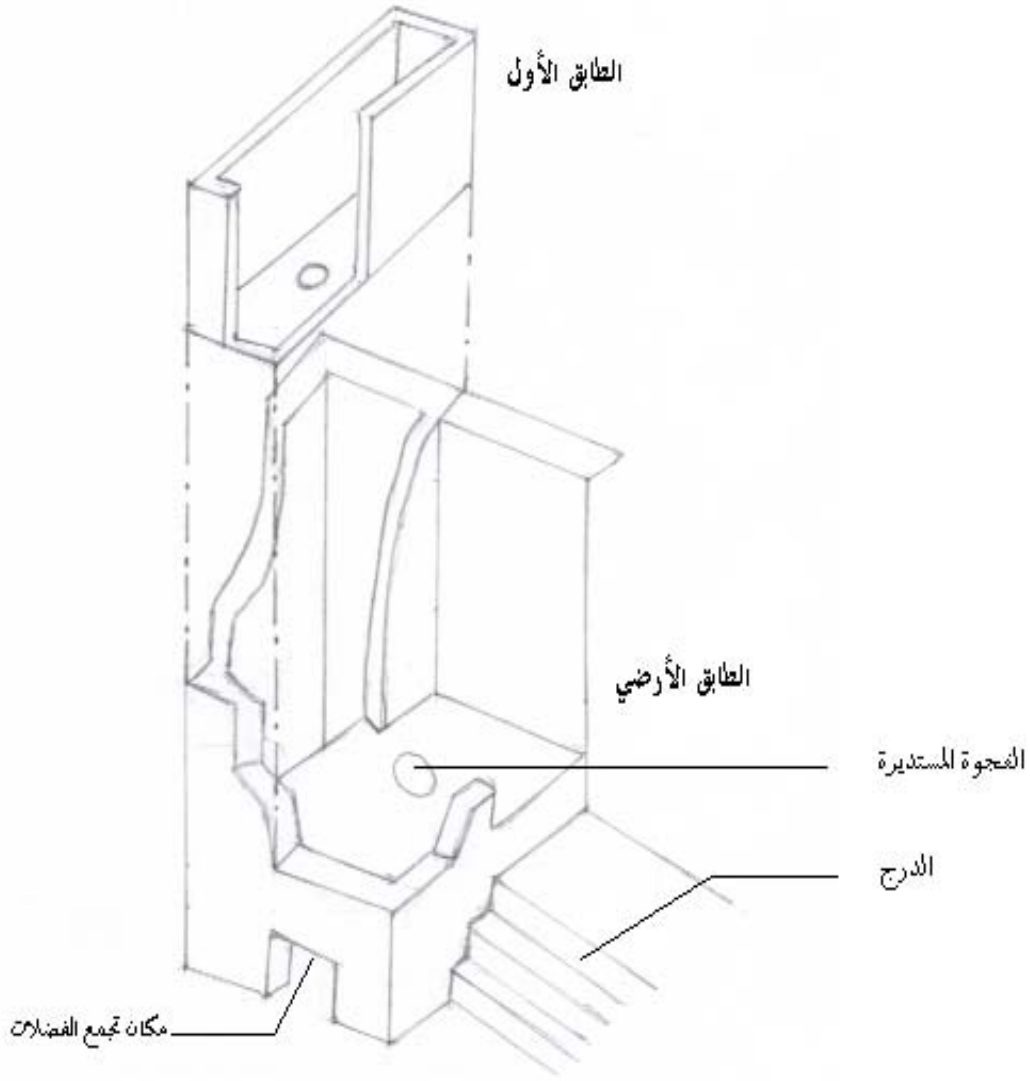

الشكل رقم (6)

يمثل كيفية بناء الكنيف

عن (B.E.T.A) Bureau d'Etudes Technique Architecture, cité 48 logts, El-Bayadh.
(بصرف)

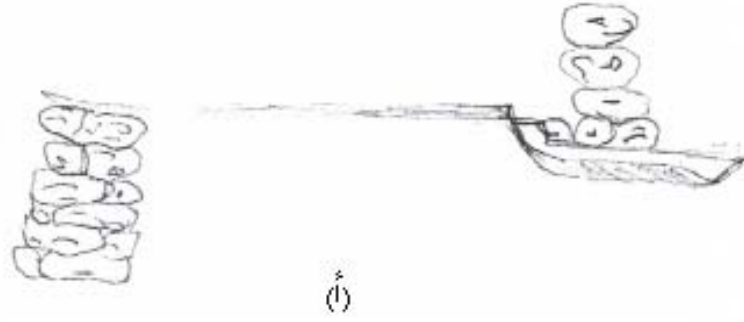

50

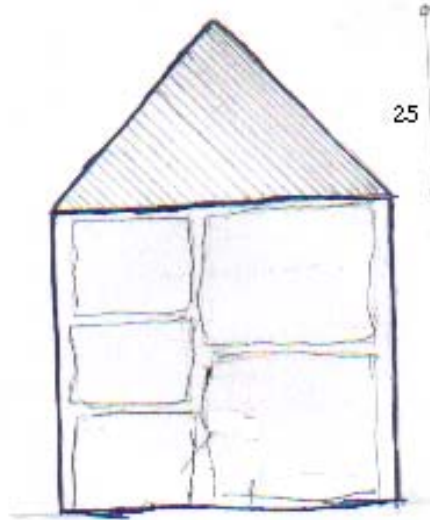

(ب)

الشكل رقم (7)
يمثل قناة تصريف المياه
(عن الطالب)

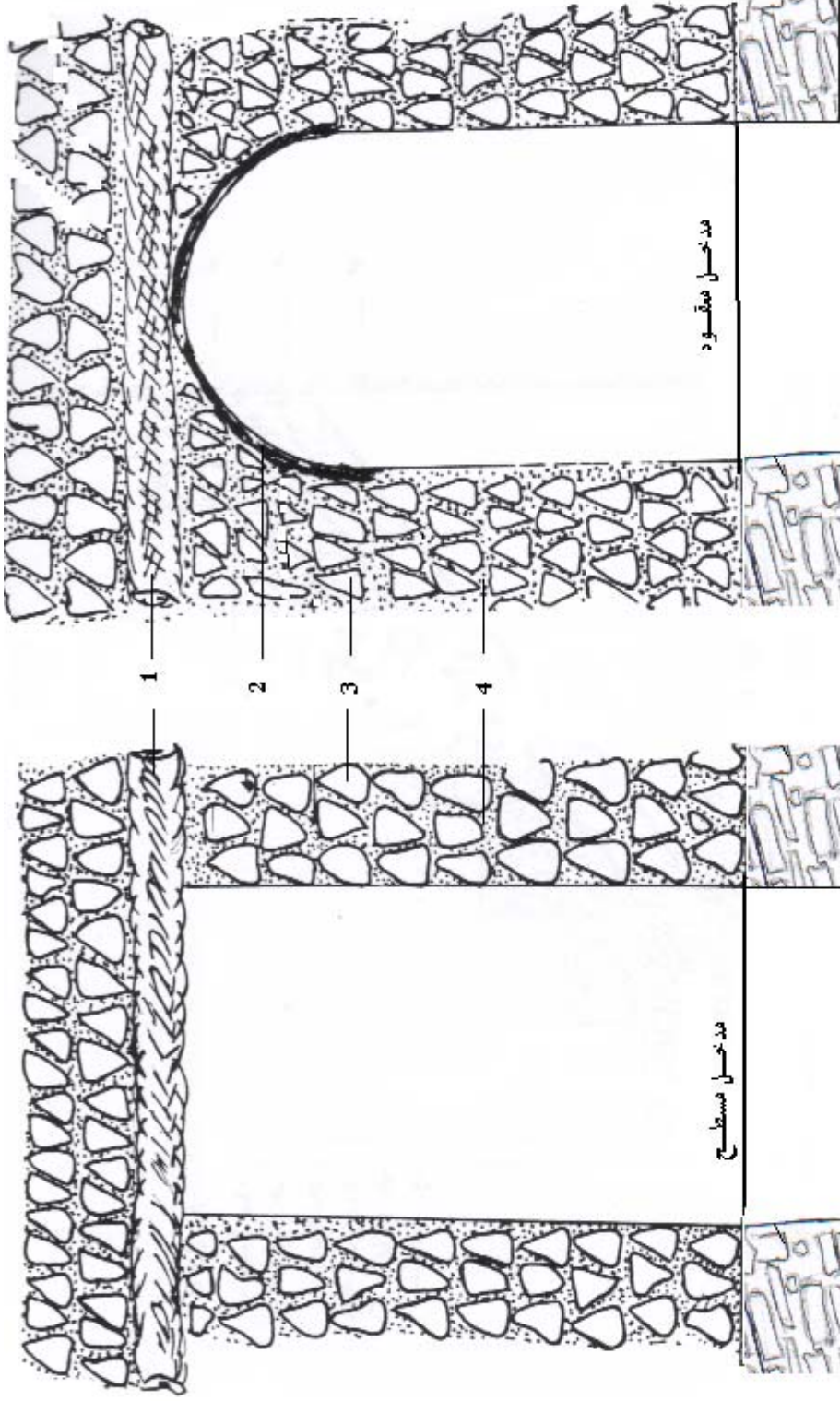

- 1 جذوع النخيل
- 2 الجرس
- 3 لبنات الطوب
- 4 السلاط الطيني

الشكل رقم (8)
 يوضح تقنية بناء مداخل المنازل
 (عن الطالب)

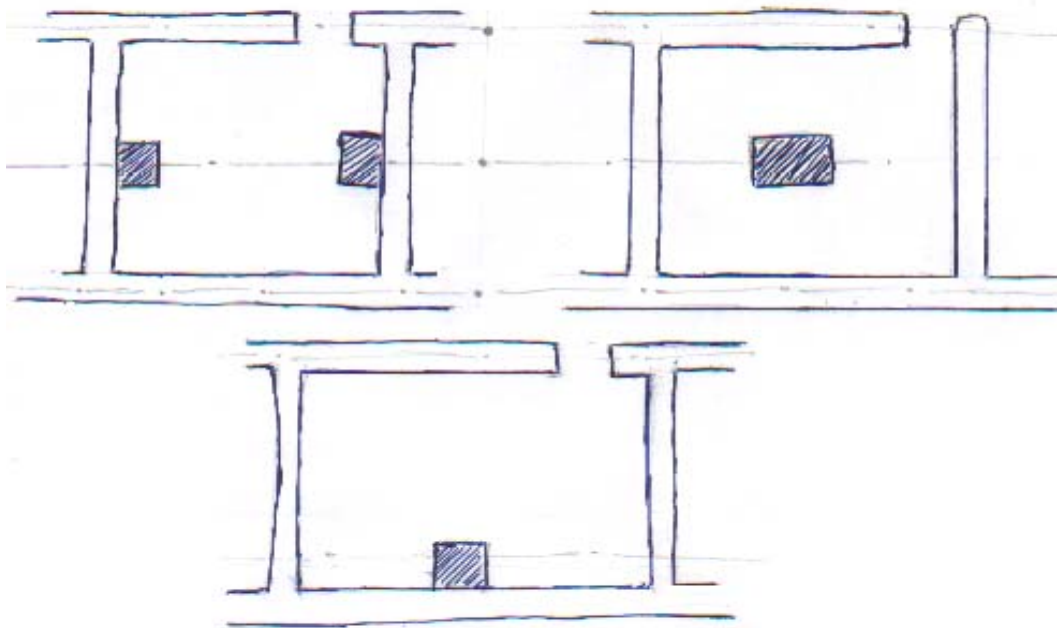
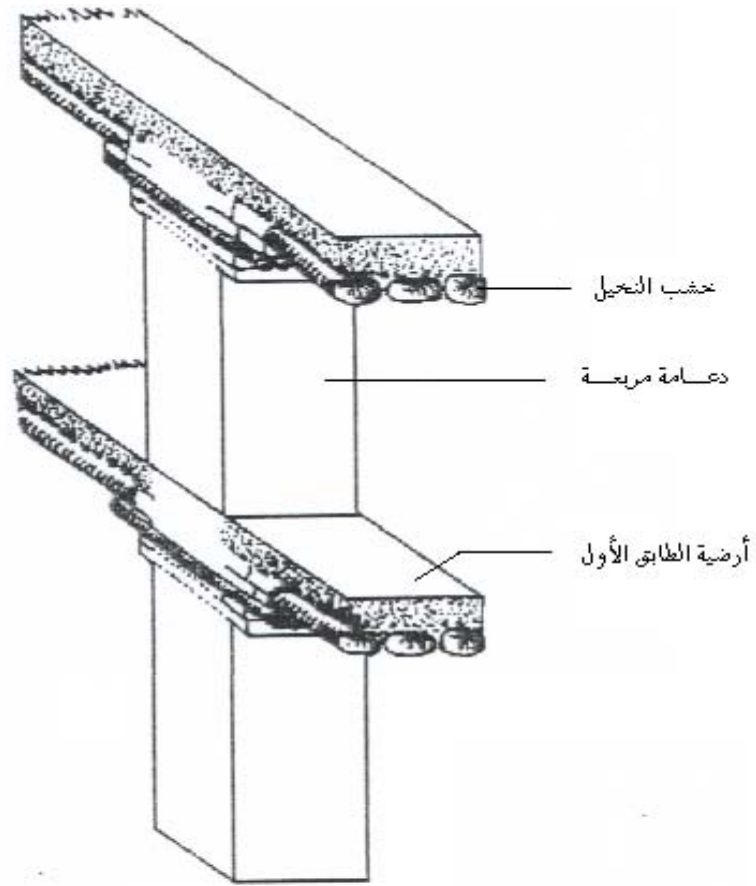

الشكل رقم (9)
 رسم تخطيطي يوضح كيفية وضع الدعامات وتوزيعها
 (عن الطالب)

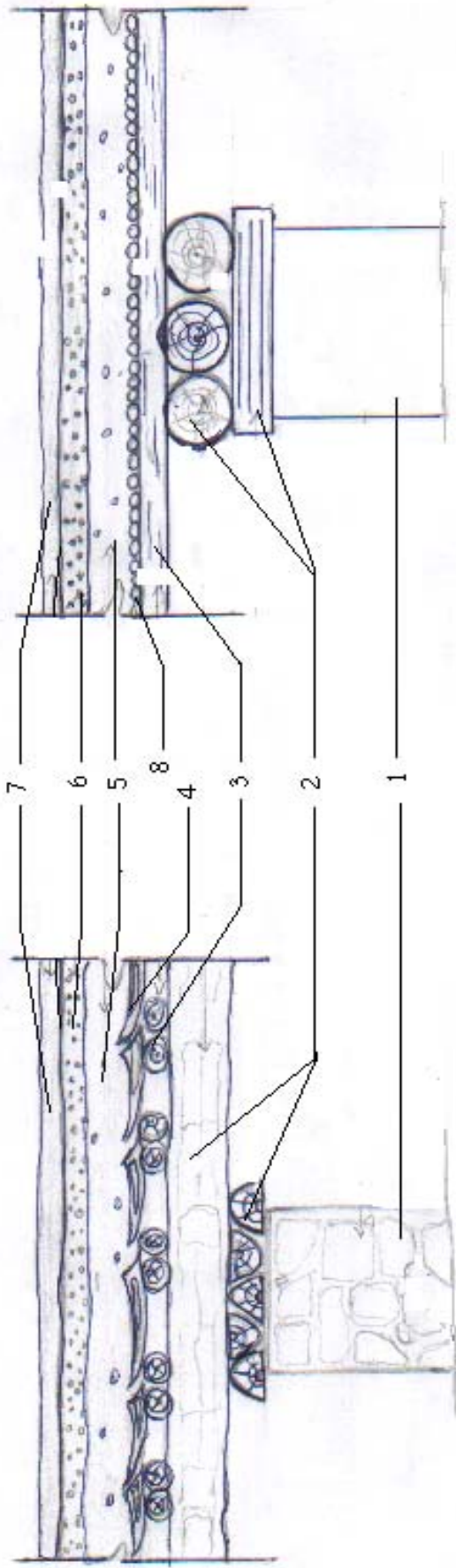

- 1- دعامة
- 2- خشب النخيل
- 3- خشب الفرعار
- 4- الفرناف

- 5- طين رطب
- 6- طين ناغش
- 7- صفايح
- 8- فصبا

الشكل رقم (10)
 تخطيط مقطعي طولي لكيفية إنجاز السقف
 (عن الطاب)



مسقط أفقي

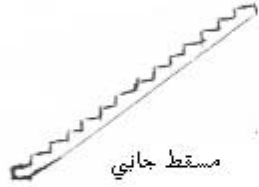

مسقط جانبي

الشكل رقم (11 أ)
يمثل درج مستقيم اتجاهه وحيد
(عن الطالب)

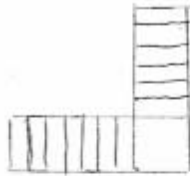

مسقط أفقي

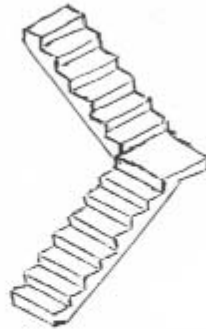

مسقط جانبي

الشكل رقم (11 ب)
يمثل درج مشابه لحرف (L) يحتوي على بسطة مربعة
(عن الطالب)

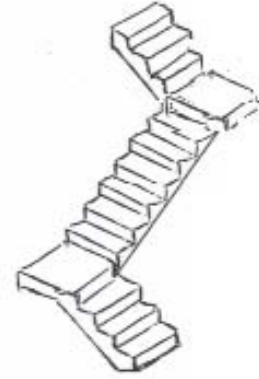
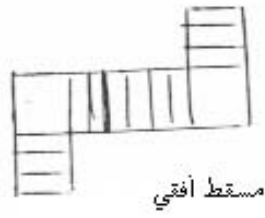

الشكل رقم (12 أ)
 يمثل درج مشابه لحرف (L) من الاتجاهين
 (عن الطالب)

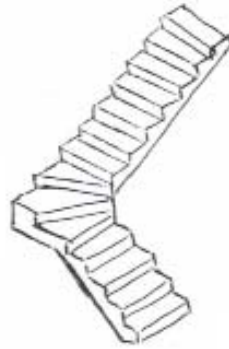

الشكل رقم (12 ب)
 يمثل درج يحتوي في وسطه على درجات ذات شكل مثلثي
 (عن الطالب)

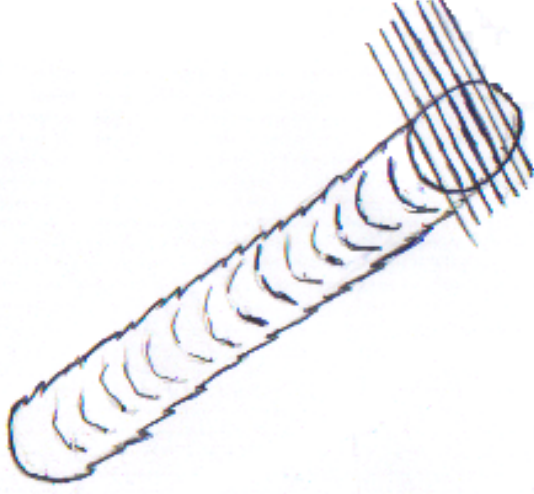
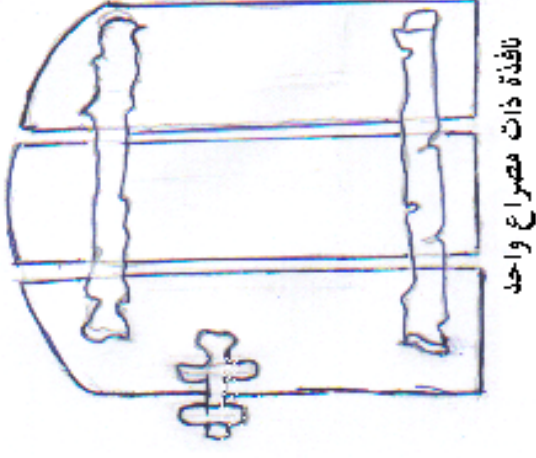

جذع النخلة مقسم على عدة أجزاء طويلة
لتهيئته لصنع النوافذ والأبواب أيضا

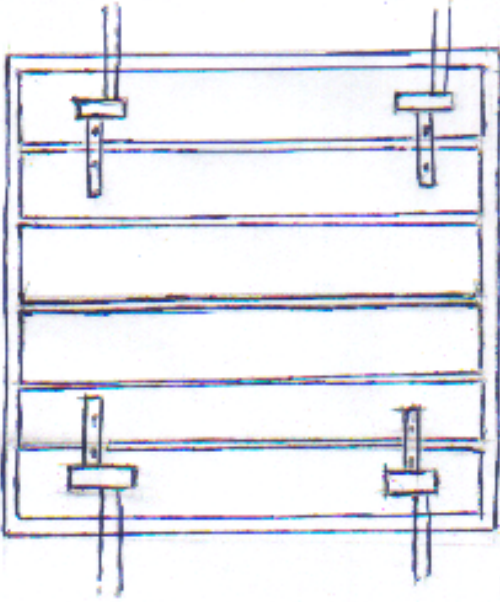

الشكل رقم (13)

يمثل طريقة صناعة النوافذ
(عن الطالب)

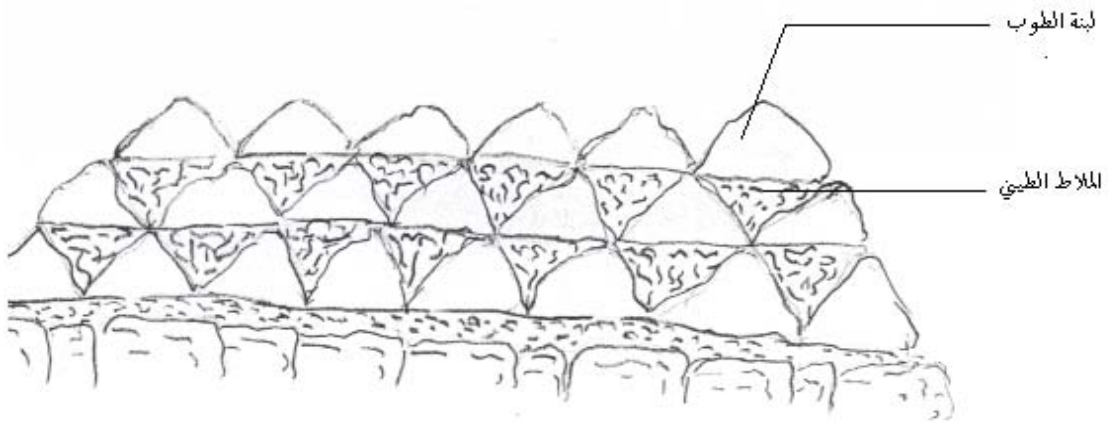

الشكل رقم (14)
 يمثل شكل لبنات الطوب وكيفية وضعها
 (عن الطالب)

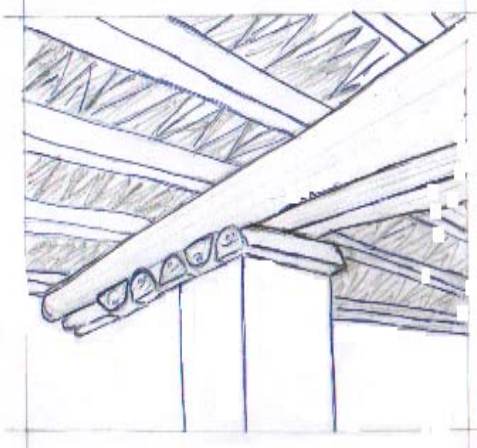

التسقيف بخشب النخيل

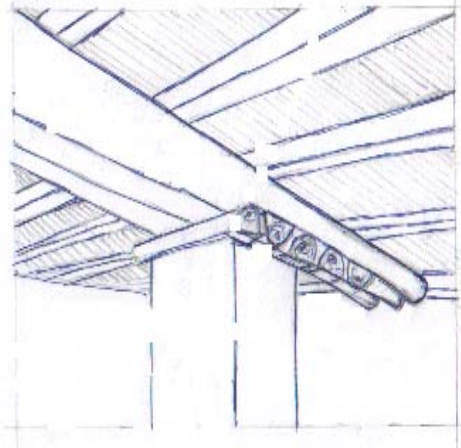

التسقيف بالقصب

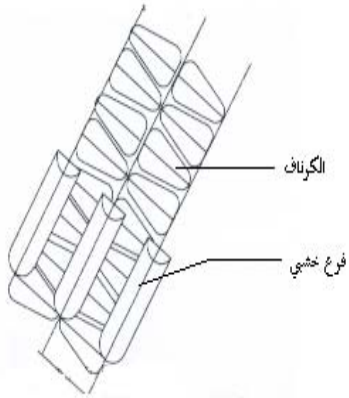

تقنية التسقيف بالكرفان

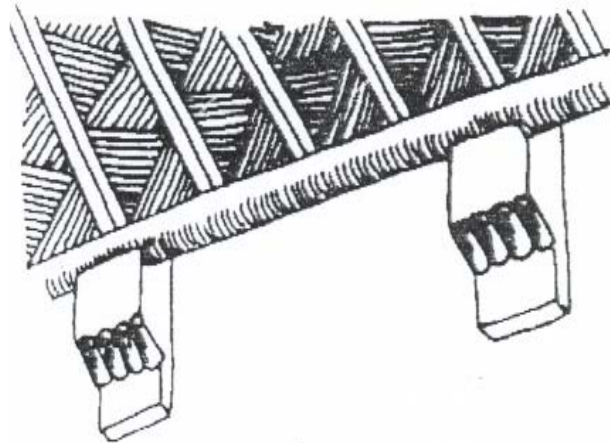

التسقيف بخشب العرعار وأعواد الذفلي في بيت الصلاة

الشكل رقم (15)
يوضح طريقة التسقيف
(عن الطالب)



ملحق المخطوثة

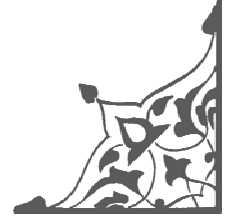
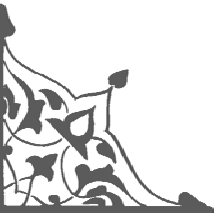

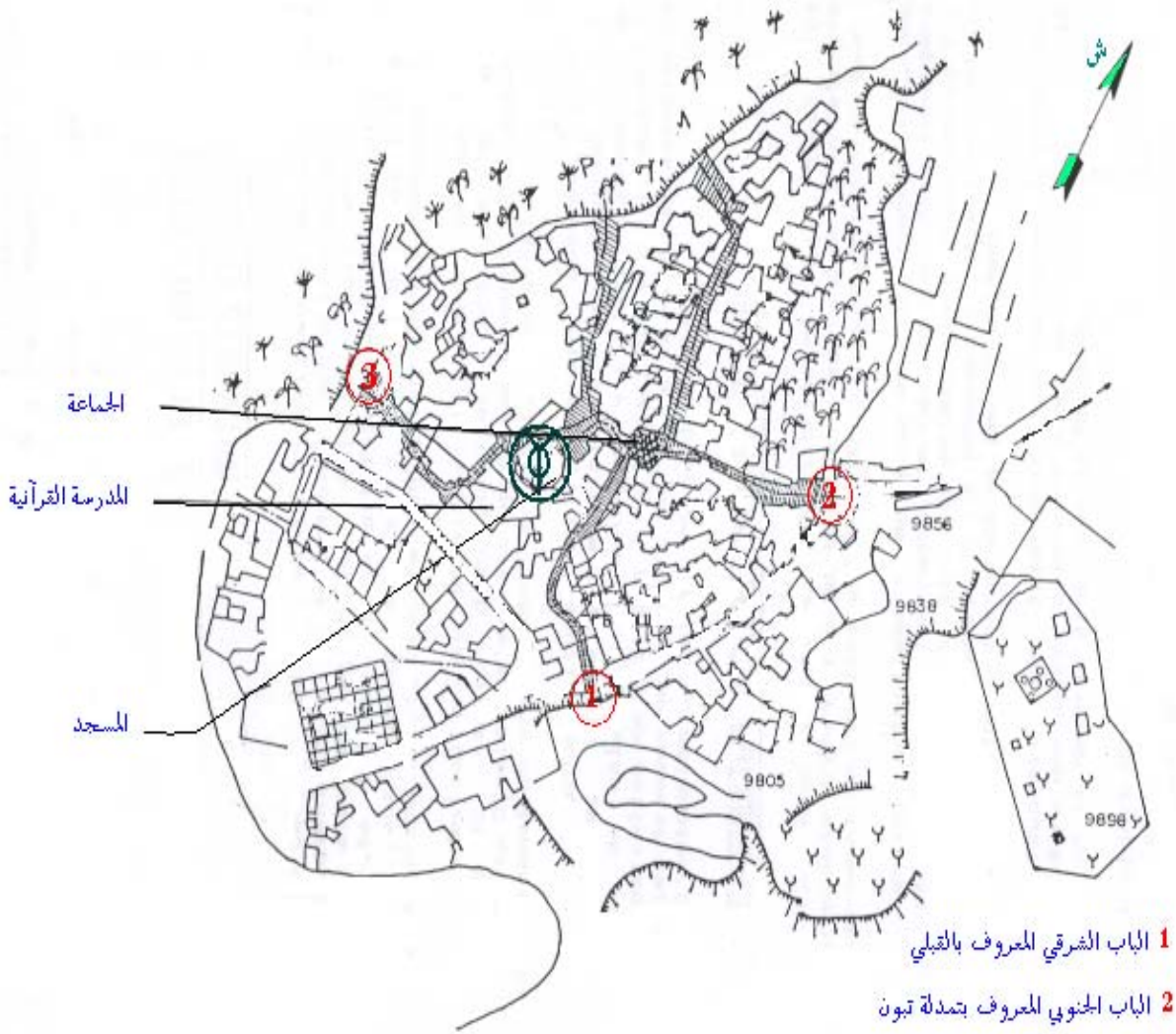

1 الباب الشرقي المعروف بالقطبي

2 الباب الجنوبي المعروف بتمدة تبون

3 الباب الغربي المعروف بأت ناسي

منحدر

مقبرة

واحة



المخطط رقم (1)

يوضح المخطط العام للقصر

عن Khaldoun Abderrahim, problematique de revitalisation d'un Ksar de l'Atlas Saharien

(بتصرف) , 1990, BOUSEMGHOUN

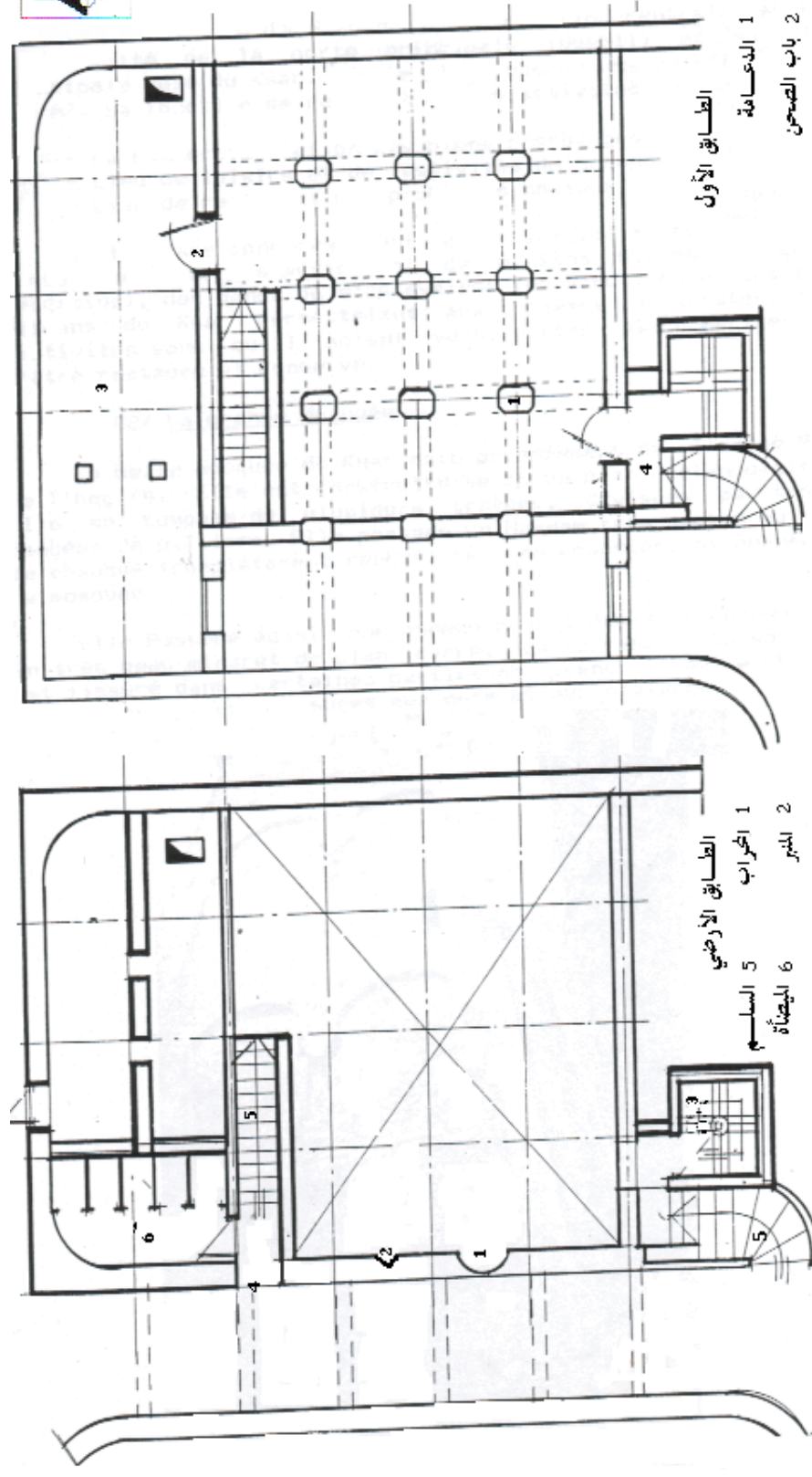

الطابق الأول

- 1 الدعامة
- 2 باب الصحن
- 3 الصحن
- 4 باب مخصص للإمام

الطابق الأرضي

- 1 الخراب
- 2 المنبر
- 3 القبلة
- 4 الباب الرئيسي لدخول المصلين
- 5 السلم
- 6 الميضية

سليم 1/100

المخطط رقم (2)

يوضح مخطط المسجد الجامع للقصر

عن خالدون Abdenrahim , problematic de revitalisation d'un Ksar de l'Atlas Saharien

بصرف) , 1990 , Cas : BOUSEMGHOUN

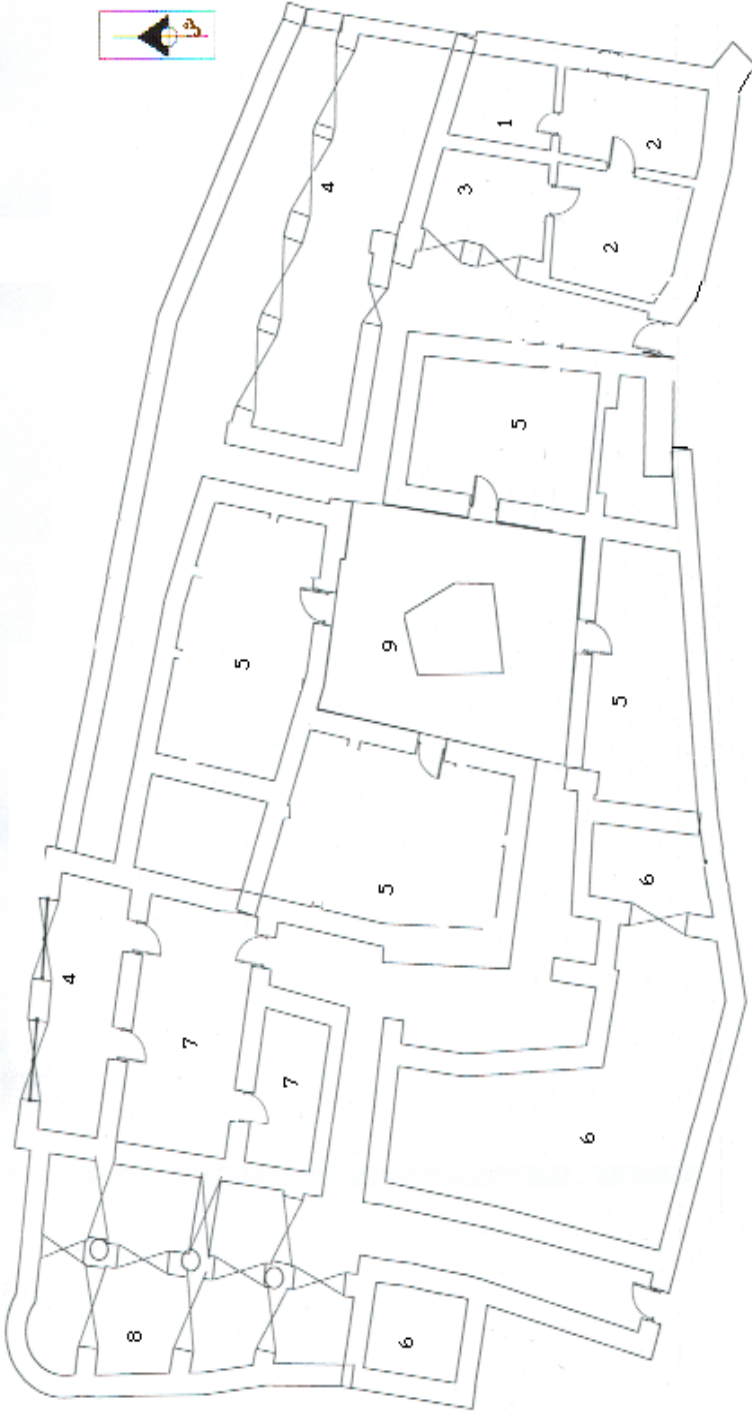

- 1 حجرة الصيد (الخلوة)
- 2 غرف تابعة للخلوة
- 3 مِسْو
- 4 الشرفنة
- 5 بيوت سكنية وتدرسية
- 6 المخزن
- 7 الدار البيضاء (بيت الصيوف)

- 8 المصلي
- 9 الفناء

200 / 1

المحفظ رقم (3)

بوضوح الراوية (المدسة القرآنية) و خلوة سيدى أحمد التجاني
Bureau d'Etudes Technique Architecture, cité 48 logts, EL-Bayadh. (B.E.T.A.)
عمان (بتصرف)



المحتفظ رقم (4)

يوضح المساحات المبنية في القنصر

عن Khaldoun Abderrahim , problematique de revitalisation d'un Ksar de l'Atlas Saharien

Case : BOUSEMGHOUN, 1990 , (بتصرف)

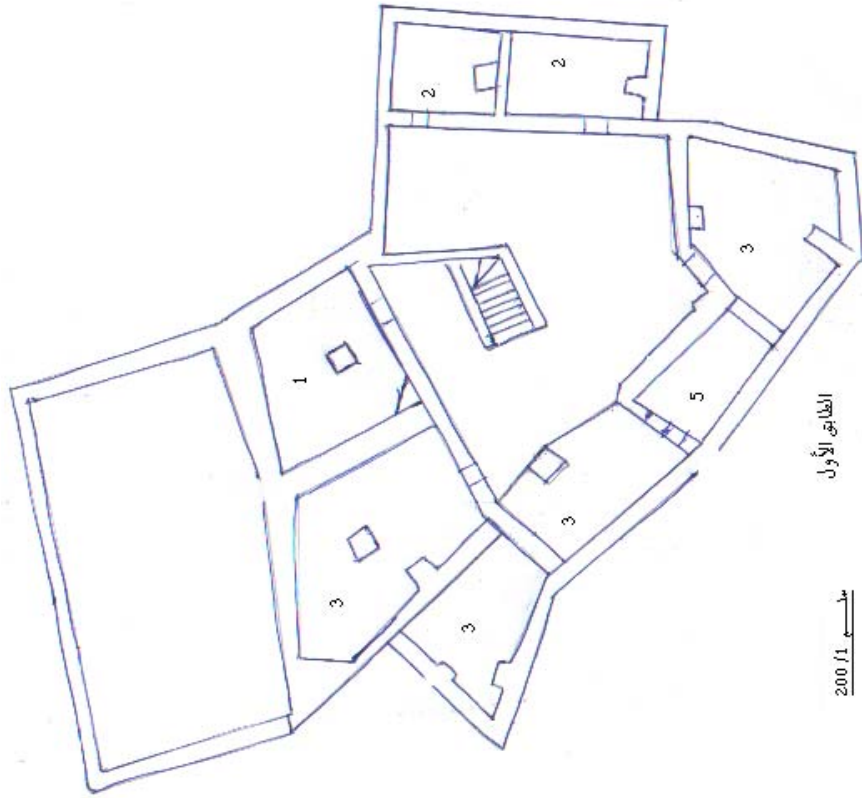

الطابق الأول

200 / 1 م

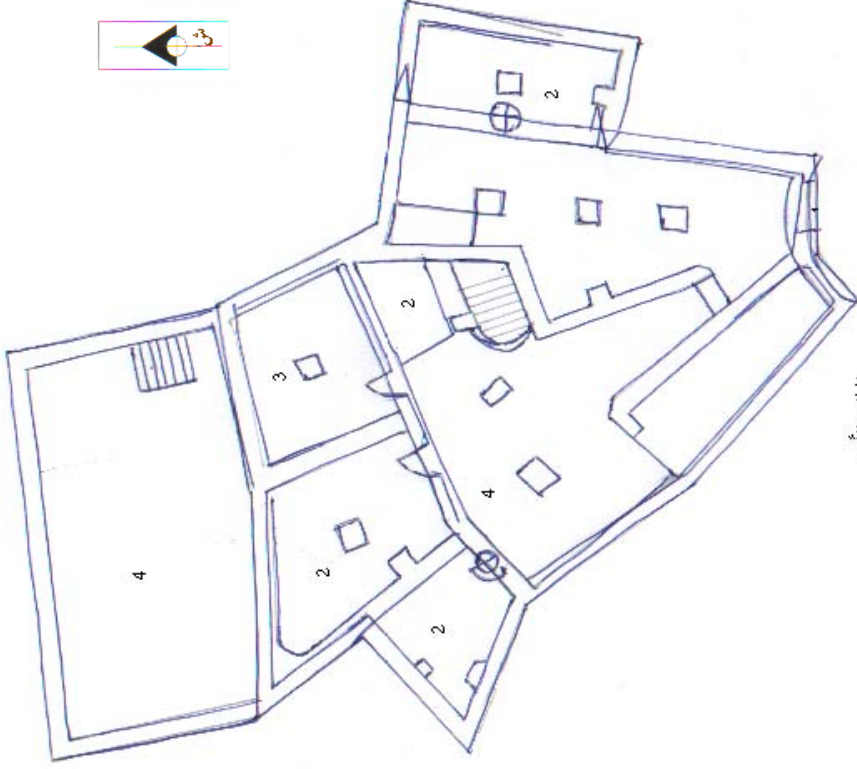

الطابق الأرضي

- 1- مطبخ
- 2- حمام
- 3- غرفة
- 4- مساحة مكشوفة
- 5- كنيش

المخطط رقم (5)
 منزل المهندس زياد البشير
 (عن الطابق)

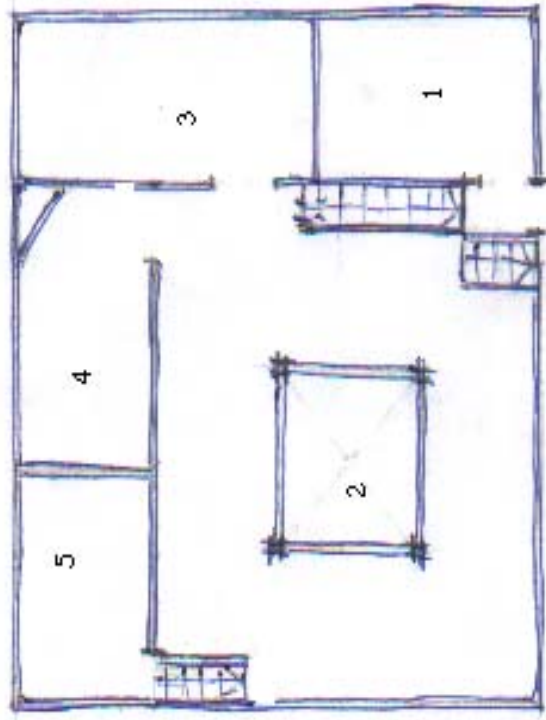

طابق أرضي

200 / 1 م

- 5- كنيش
- 6- غرف
- 7- غرفة الضيوف
- # دعامة

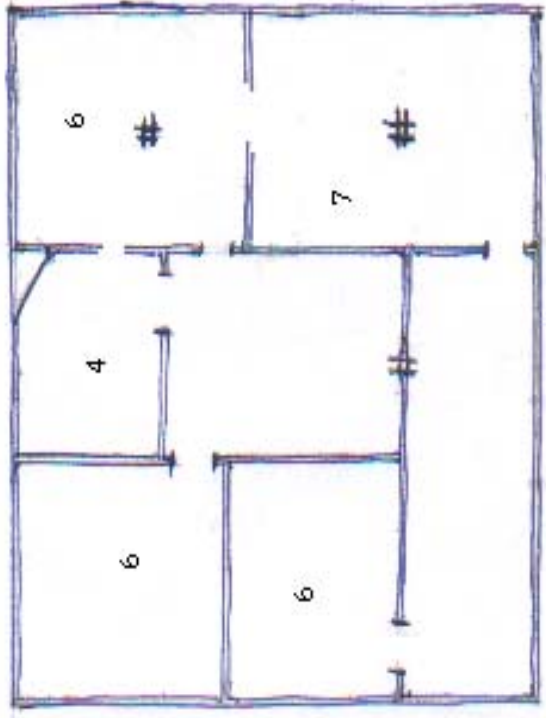

الطابق الأول

- 1- مخزن
- 2- مساحة مكشوفة
- 3- اصطبل
- 4- مطبخ

المحفظ رقم (6)
 يمثل منزل القائد هو زيان
 (عن الطاب)

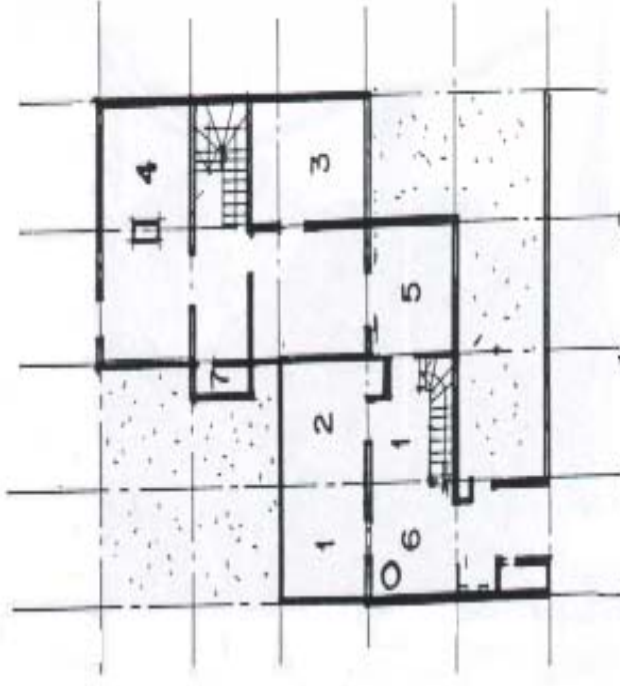

الطابق الأرضي

- 1 غرف
- 2 بيت الضيف
- 3 غرفة نوم
- 4 اسطبل
- 5 مطبخ
- 6 بئر
- 7 كيبف

200 / 1 ملليم

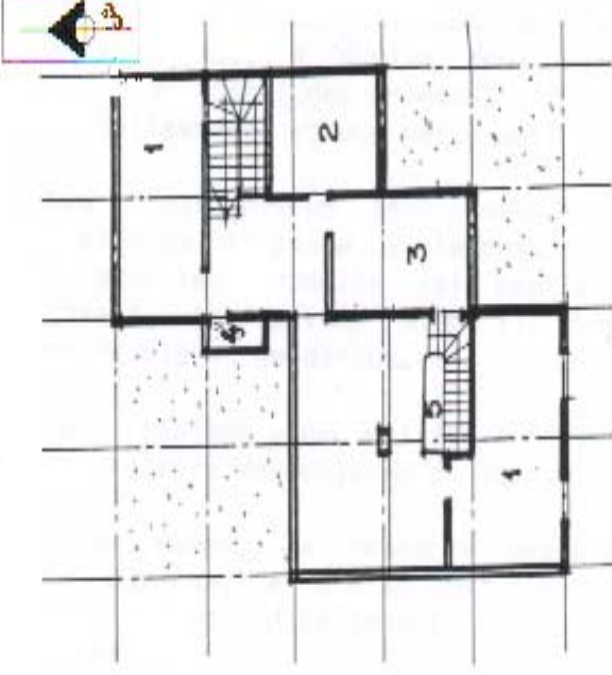

الطابق الأول

- 1 غرفة الضيف
- 2 مطبخ
- 3 غرفة نوم
- 4 كيبف
- 5 فراغ

المنحطظ رقم (7)

يوضح منحطظ منزل في حي أكرم جديد

عن Khaldoun Abderrahim , problematique de revitalisation d'un Ksar de l'Atlas Saharien
(بصرف) , Cas : BOUSEMGHOUN, 1990 ,

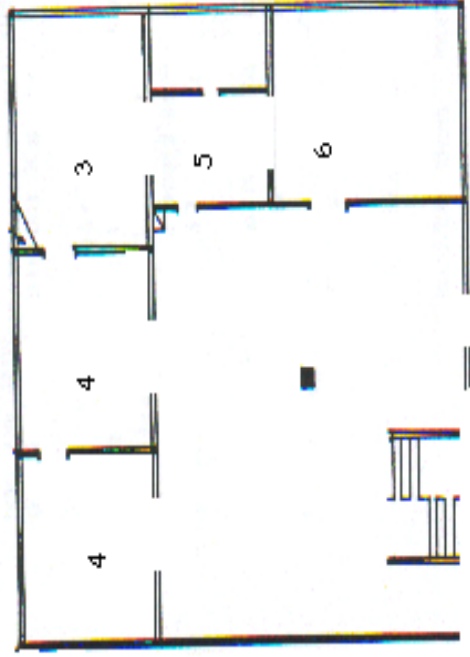

- 5- كنيش
- 6- اصطيبل
- 7- فناء مكشوف
- دعامة

200 / 1 م

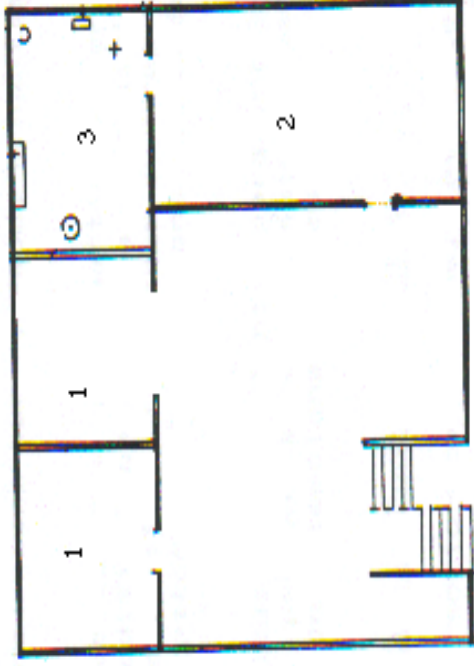

- 1- غرف نوم
- 2- غرفة الضيوف
- 3- مطبخ
- 4- مخزن

المحفظ رقم (8)

يوضح مخطط منزل في حي نت أوسليمان

Khaldoun Abderrahim , problematique de revit alisation d'un Ksar de l'Atlas Saharien

(بتصرف) , 1990 , BOUSEMIGHOUN , Cas :

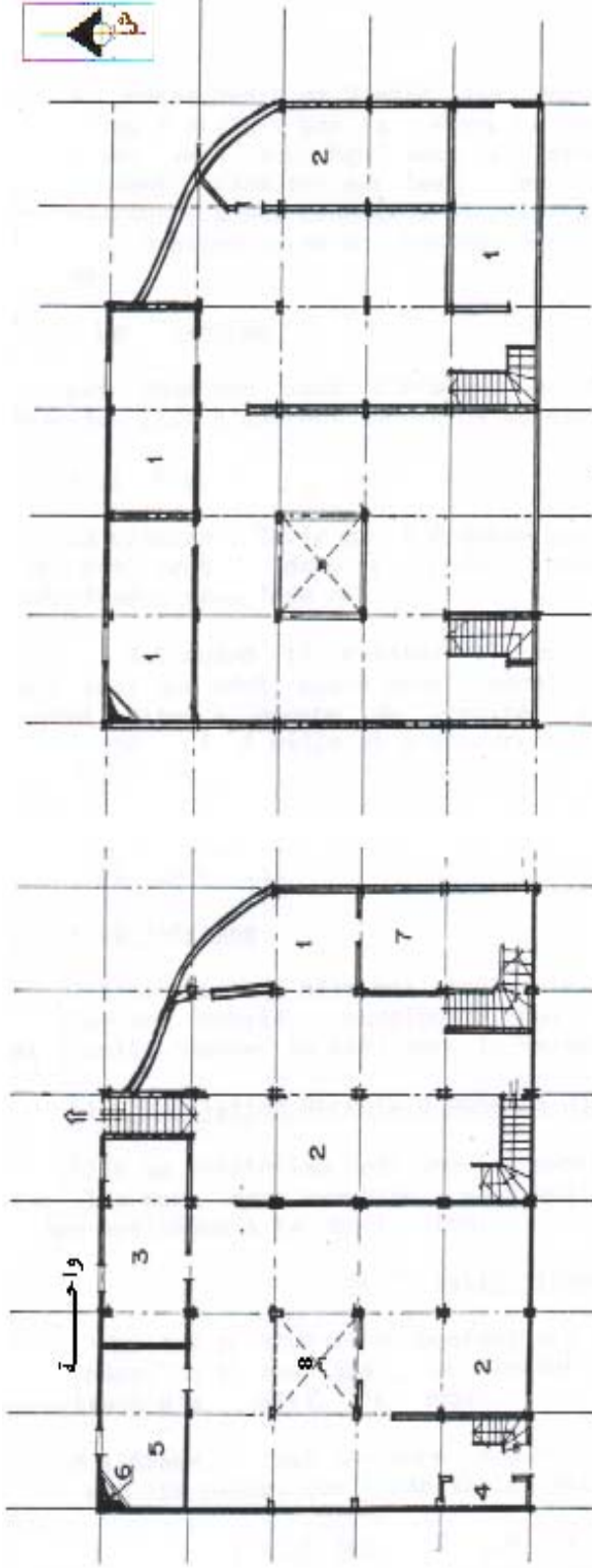

الطابق الأرضي

الطابق الأول

- 1 الإسطبل
- 2 مساحة مخصصة للحيوانات
- 3 غرفة
- 4 بئر وحوض للماء
- 5 مطبخ
- 6 مدفأة
- 7 كنيش ومخزون
- 8 مساحة مكتنوفة

- 1 غرف
- 2 مطبخ

المخطط رقم (9)

يوضح مخطط منزل في أغزم أقدم

Khaldoun Abderrahim , problematique de revit alisation d'un Ksar de l'Atlas Saharien

Cas : BOUSEMIGHOUN , 1990 , (بصرف)



شوارع رئيسية

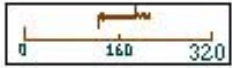

المخطط رقم (10)

يوضح الشوارع الرئيسية الثلاثة

عن Khaldoun Abderrahim, problematique de revitalisation d'un Ksar de l'Atlas Saharien

(بتصرف), 1990, BOUSEMIGHOUN

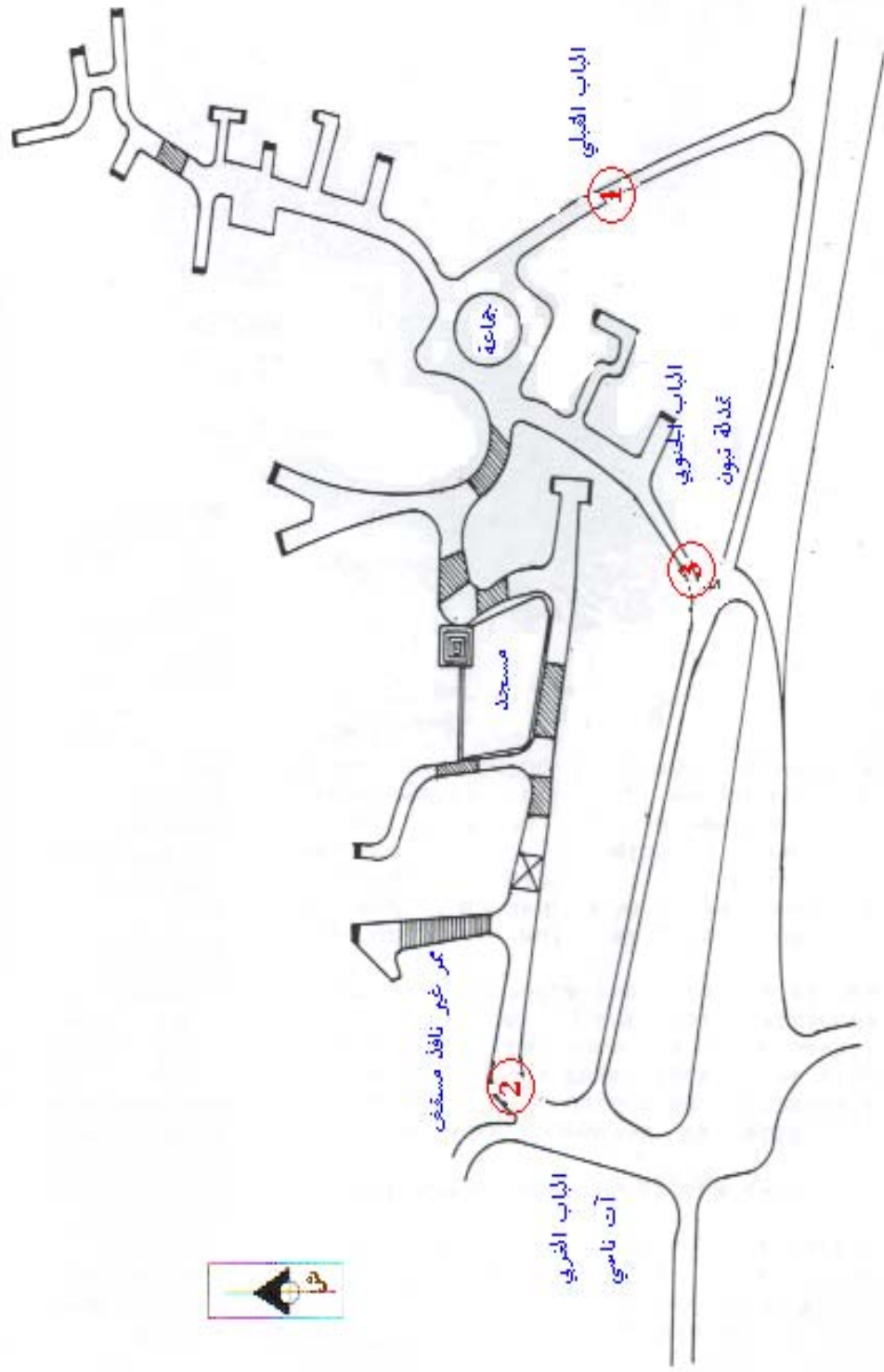

المخطط رقم (11)

يوضح الممرات المغلقة و المسقفة للقصر

Khaldoun Abderrahim , problematique de revitalisation d'un Ksar de l'Atlas Saharien

عن (بصيرف) , 1990 , BOUSEMGHOUN

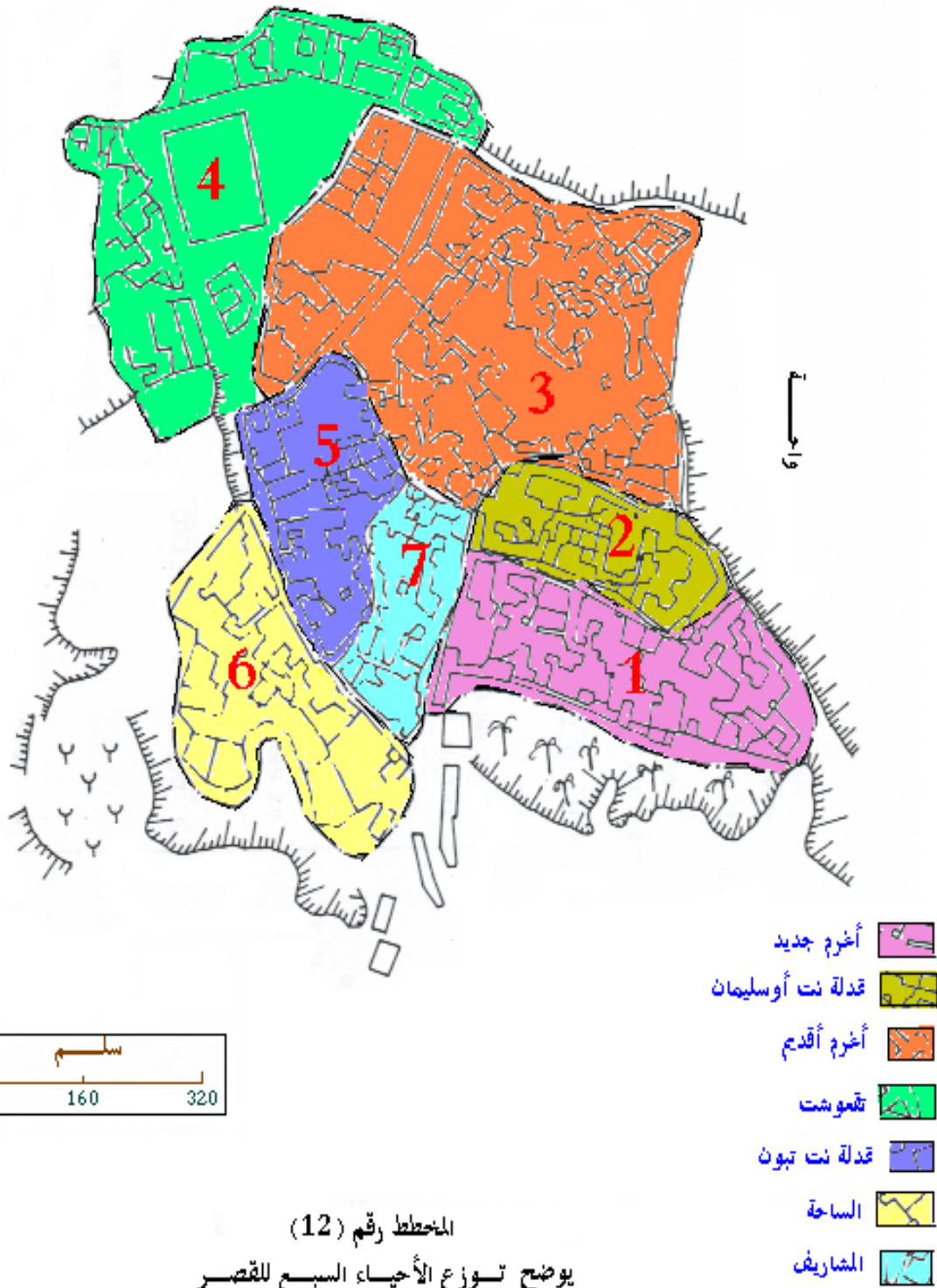

المخطط رقم (12)

يوضح توزيع الأحياء السبع للقصر

عن Khaldoun Abderrahim, problematique de revitalisation d'un Ksar de l'Atlas Saharien

(بتصرف)، 1990، BOUSEMGHOUN، Cas

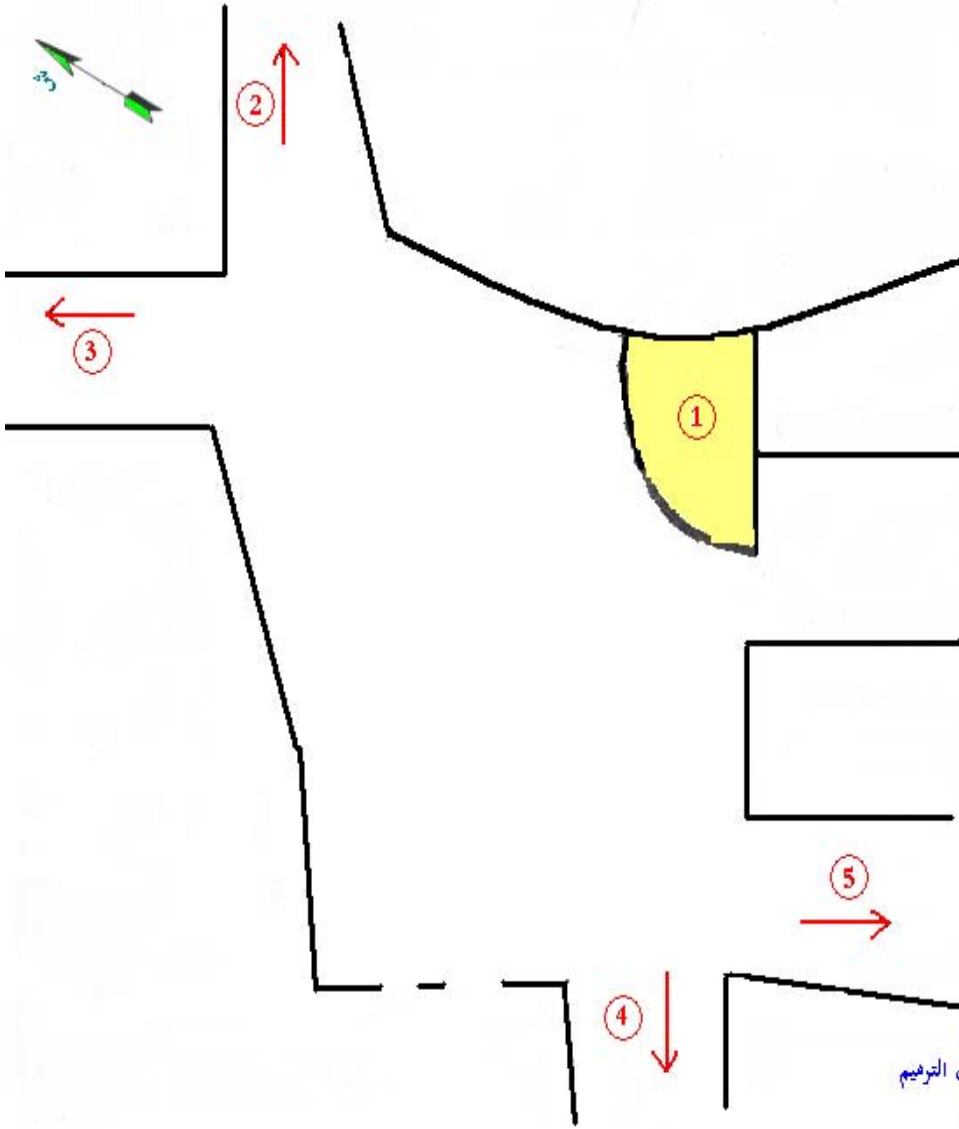

- 1 نافورة شيدت مؤخرا أثناء أعمال الترميم
- 2 الشارع المؤدي إلى الباب القبلي
- 3 مفلذ يؤدي إلى حي أكرم جديد
- 4 الشارع المؤدي إلى الباب الغربي المعروف بآت ناسي
- 5 الشارع المؤدي إلى الباب الجنوبي المعروف بتمدلة تبون

المحطظ رقم (13)
يوضح ساحة الجماعة
(عن الطالب)



ملحق الخرائط

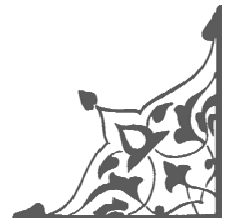

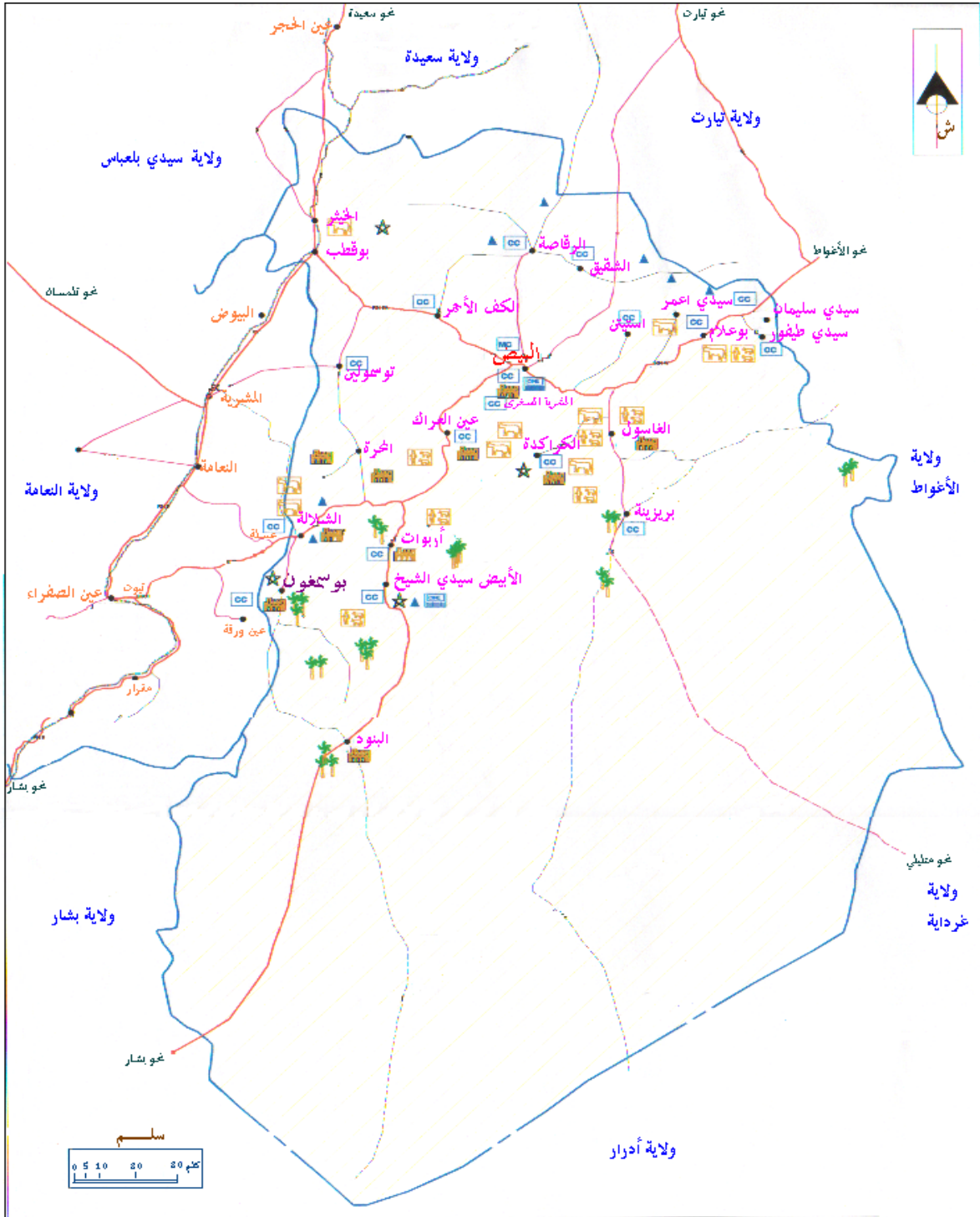

رسوم حجرية	محطات معلومة	سمسما	طرق وطنية
محطات حجرية مهيجرة	قصر قديم	مركز ثقافي	طرق ولائية
محطات تاريخية	واحة نخيل	دار الثقافة	طريق غير ممعبدة
			محاور في طور الإنجاز
			حدود الولاية

الخريطة رقم (1)

خريطة البيض توضح أهم المحطات الأثرية ، التاريخية والثقافية

(بتصرف)

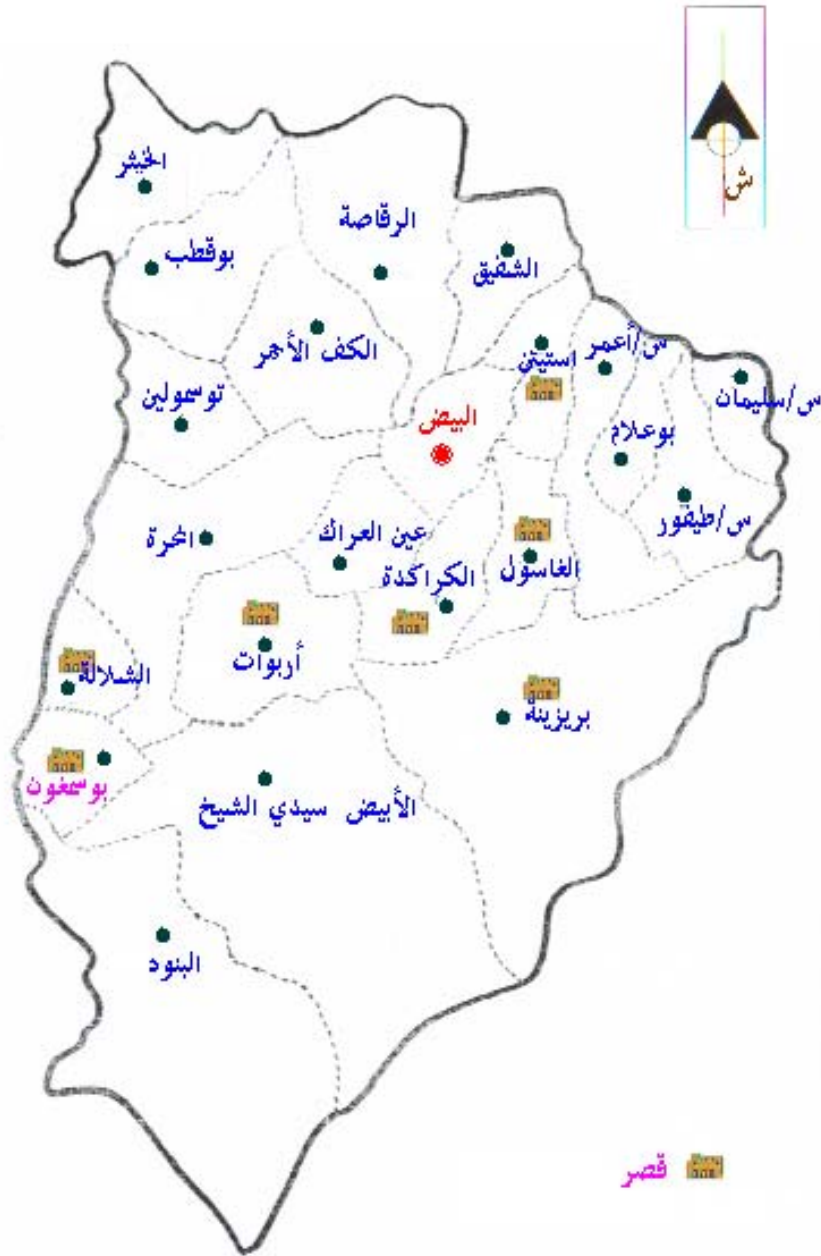

سالم
1/250 000

الخريطة رقم (2)
خريطة توضح توزع القصور عبر تراب الولاية
(عن الطالب)



سالم
1/250 000

الخريطة رقم (3)
خريطة توضح توزع الجبال والأودية
(عن الطالب)

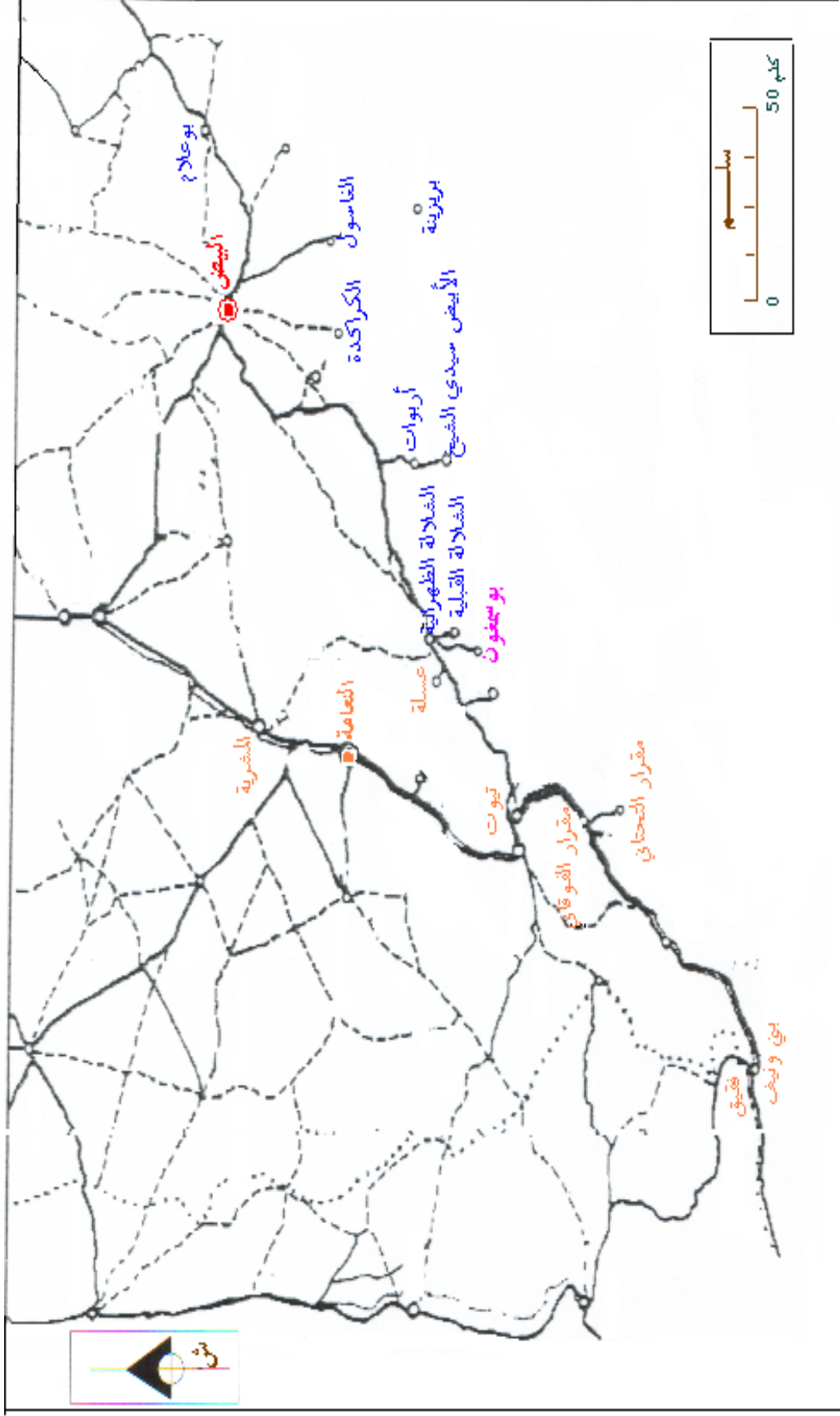

الخريطة رقم (4)
 القصرى الحصنة بجبال القصور
 COMINARDI (F), Au coeur des monts des KSOUR ,
 عمان (عصرف) . 10 , P 1996 , Le K.S.A.R. de Chellala Dahrani

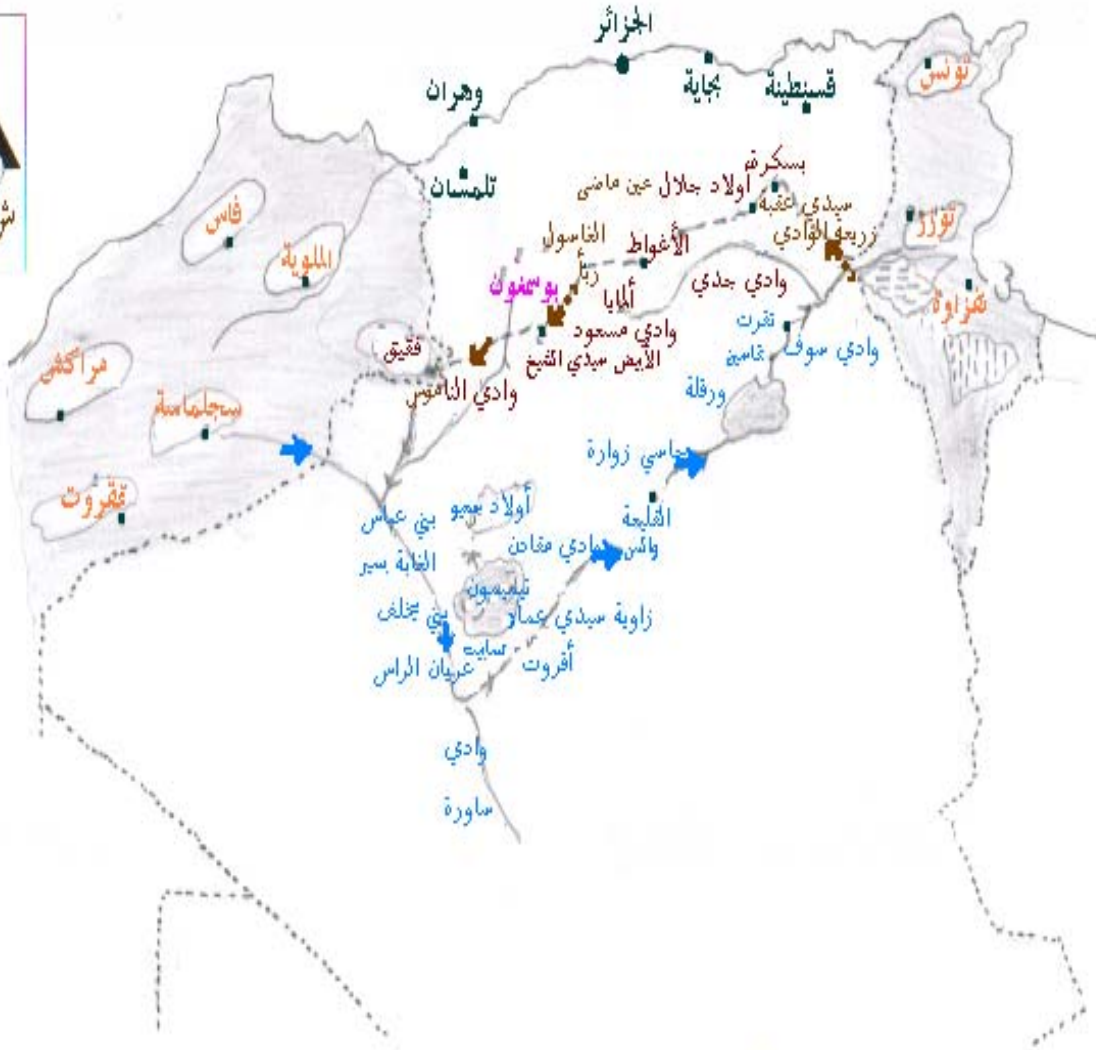

—— طريق الذهاب إلى المشرق

- - - طريق العودة إلى المغرب

الخريطة رقم (5)

خريطة توضح رحلة العياشي إلى الحج

عن الخميس، الجزائر من خلال رحلات المغاربة في العهد العثماني، الجزائر، 1979م

(بتصرف)



ملحق الأوراق





(1)



(2)



(3)



(4)



(5)



(6)



(7)



(8)



(9)



(10)



(11)



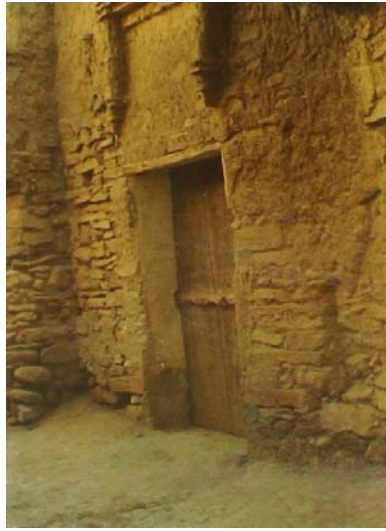

(13)

()



“ ”



“ ”



()

(14)

“ ”



(15)



(16)

()



(17)
()

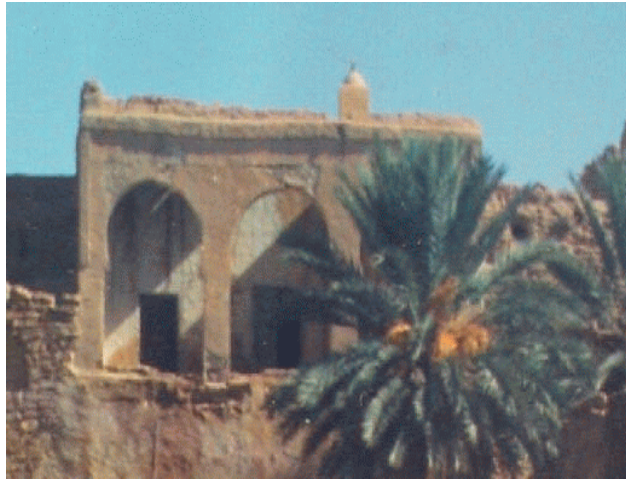





(20)



(21)

()



















(30)



(31)

()



(32)

()



()











(39)



()







(43)







(46)



(47)





الفهارس

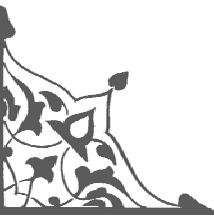

85		1
86		2
87		3
88		4
89		5
90		6
91		7
92		8
93		9
94		10
95	(L)	11
96	(L)	12
97		13
98		14
99		15

100		1
101		2
102	()	3
103		4
104		5
105		6
106		7
107		8
108		9
109		10
110		11
111		12
112		13

فهرس الخرائأ

113		1
114		2
115		3
116		4
117		5

118		1
119		2
120		3
121		4
122		5
123		6
124		7
125		8
126		9
127		10
128		11
129		12
130	()	13
131		14
132		15
133	()	16
134	()	17
135		18
136		19
137		20
138	()	21
139		22
140		23
141		24
142		25

143		26
144		27
145		28
146		29
147		30
148	()	31
149	()	32
150		33
151		34
152		35
153		36
154		37
155		38
156		39
157		40
158		41
159		42
160		43
161		44
162		45
163		46
164		47
165		48

فهرس الآيات القرآنية

7	«. ...»	10	
7	« ...»	73	
27	»: «	31	
27	» «	108	
30	« ... »	37	
30	« ... »	39	
33	« »	27	
58	« »	78	

البلدان

ب
23 22 17 8 5 4 2 1
12 9 2 1 ()
41 23 ()
8
25 4
10 9 8 6 5 4 3 2 ()
20 19 18 17 15 14 13 12
73 70 68 64 34 62 35 30 22
84 83 82 76 79

9
77

ت
39
13 12 9 ()
12 9 ()
22 18
40
22
42 40 39
25

ج
39
22
24 11 8
13 ()
38
38 32
11 8
20 11 8 5 4

أ
19
22 10 9 8 2 ()
39
17 9 2 ()
9 2 ()
12 ()
33
11 7 2 ()
9 ()
62 19
11 ()
23
40
24
8 ()
18
10 ()
10 ()
10 ()
10 ()
13 ()
10 ()
11 ()
18 10

فهرس الأماكن والبلدان

ش		خ	
39		15	()
17 15 10 9 8 2	()	ح	
8	()	24 18	
8	()	17	
ص		د	
22 4		38	
25	()	ر	
ض		19	
17		77	()
ط		ز	
38		39	
39		39	
ع		39	
17	()	39	
39		39	
8		39	
11 9 8 5	()	40	
40 22 21		40	
غ		40	
9 2		40	
12	()	12	()
ف		س	
31		18	
19 4		12 9	()
64 41 39 22 21 4		42	
		38 18	
		33	
		13	()
		13	()
		17	()

ج
 15 5
 5
 8
 ح
 3
 خ
 21
 د
 4
 37 36 9 4
 ر
 33+35 31 27+30 ص
 64
 25 4
 ز
 25 8
 س
 39
 40
 23 21+22 20
 64 41 40 35 24
 20 19
 20 18
 20
 21
 21
 40
 21

ا
 33 3
 33
 3
 10 3
 31
 37
 39 ()
 20
 39
 41 22
 21
 39
 20
 39
 39
 39
 3
 5
 20 4
 4
 ب
 33 3
 21
 20 17 ()
 9
 ت
 17
 40 24
 4

فهرس الأعلام والشخصي

ل	ط
18 4	23
8	
م	ع
5	21
21	37 ()
23	21
23	38
23	31
23	38 31
21	19 12 3
22	ف
18	20
31	ك
ك	4
77	4
	18 5



المراجع المصادر:

القرآن الكريم .

أ-تاريخ ورحلات وفقه

:()

. 1992

_____ ●
:

:()

_____ ●
:()

. 1998

1 ()

_____ ●
:

. 1960

1

:()

2

_____ ●
:()

. 1981

:()

. 1981

_____ ●
2

:()

. 1957

:()

. 1913

:()

1

:()

. 1966

1

:()

. 1946

:(

)

. 1961

1

:()

2 1

. 1977 2

:()

. 1892

1

:()

. 1960

:()

1957

:()

. 1960

:

2

:()

1983

ب-قواميس ومعاجم

:()

. 1993

11 6

:()

3

1998

:()

1

. 1974

1 2

:()

. 1962

9

:()

. 1995

11 1

:()

2

. 1993

:()

1950

:()

. 1995.

2

3

: المراجع
أ- تاريخ آثار وفنون

:()

. 1966

:()

. 1979

:()

1

1954

1931

. 1994

:()

. 1996

:()

. 1992

1

:()

•

. 1981

:()

•

. 1981

:()

•

. 1998

1

:()

•

.1977

:()

•

. 1983

6 4

:()

•

. 1984

:()

•

. 1965 30

:()

•

1

. 2002

:()

•

:()

(20-16)

. 1985

2 1

:

. 1996

:()

.. 1970

:()

. 1949

:()

. 1961

:()

. 1968

:()

. 1988

:()

. 1988 1

ب-المقالات

:()

. 124 ... 112 2001

ج- قاميس ومعاجم

:()

. 1995

•

:()

1

•

. 2000

. 1988

17

:()

. 2000

•

. 1986

21

:()

4 1

•

. 1994

:()

. 1985

•

:()

1988

1

•

. 1974

6

:()

2

•

:()

. 1999

•

د- رسائل جامعية

:()

. 2000

•

المراجع باللغة الفرنسية

- **Accardo(F),**
1879 , Répertoire alphabétique des tribus et duars de l'Algérie Alger .
- **Augustin (B),**
SD, Atlas d'Algérie et de la Tunisie , Algérie.
- **Augusta Bernard Et Lacroix (N),**
1900, Pénétration saharienne , Girart imprimeur – photos –graveur , rue 17 des colons Alger.
- **Bourouiba (R),**
1987, Rapports de l'Algérie architecture religieuses arabo islamique , O.P.U ,
Alger .
- **Campillo (Capitaine),**
SD, Le tourisme dans le cercle de Ain-Sefra, ou Un itinéraire touristique
d'Alger à Ain-Sefra, imp. Rives, Romeu.
- **Cominardi (F),**
Juin 1994, Au coeur des monts des ksour le ksar de Chellala Dahrania .
- **Cornet (A),**
1952 , Monographies régionales, L'atlas saharien sud oranais , Alger .
- **Daumas (l.c.),**
1845 , Le Sahara Algérien études géographiques, statistiques et historiques
sur la région au sud des établissements français en Algérie, fortin Masson et
Cie , paris ,Alger.
- **Daumas (M) ,**
1847 , La Grande Kabylie , études historique , Alger .
- **Despois (j),**

1957, Le Djebel Amour, presses universitaires de France Paris .

- **Duvyrier(h)**,
S.D , Historique exploration au sud –ouest de Géryville , Alger .

- **Geay(M)**,
1 mars 1935 , Etudes médicales de l'annexe de Géryville.

- **Gouvernement Général**,
1937, De L'Algérie, répertoire statistique des communes de l'Algérie, territoires du sud, décembre 1936, Ancienne Impr. Victor Heintz, 41 rue Mogador, Alger

- **Henri (L)** ,
1970, Les Gravures rupestre du sud oranais ,arts et metiers graphiques ,18 rue Seguier ,Paris 6,

- **khaldoun (A)**,
1990 , Problématique de revitalisation d'un ksar de L'atlas Saharien ,cas BOUSSEMGHOUN .

- **Kiva** ,
1894 , En Algérie (Souvenirs) , éditeur militaire ,Henri Charles , lavauzelle , 11 place Saint André des arts , Paris .

16- Leclerc (L),
1858, Les oasis de la province d'Oran ou Ouled Sidi Cheikh,tissier libraire éditeur , rue Bab El-Oued ,Alger.

- **Lehuraux (I)** ,
1931, Le Nomadisme et La colonisation dans les hauts de l'Algérie ,Paris.

- **Lehuraux (I)**,
05 mais 1934, Le Sahara ses oasis , Illustration de Leon carre , ed. Boconier , Alger.

- **Marçais (G)**,
1981 , L'art musulman , presses universitaires de France , Paris .

- **Mathea Gaudry**,
1961, La société féminine au Djebel Amour et au Ksel ,Alger.

- **Pottier (R),**
1947 , Histoire du Sahara , Paris

- **Raymond Couderc,**
Sd , Les hautes steppes sud -oranaises , université Paul Valery Montpellier,

- **Rene Maire ,**
1916 , La Végétation des montagnes du sud oranais , Alger .

- **Rinn (L),**
1884 , Marabouts et Khouan , étude sur l'Islam en Algérie , Adolphe Jouradan, Alger .

- **Rinn(L),**
1886 , Nos frontières sahariennes ,Alger.

- **Roger duvollet,**
1983 , d'Alger à Tamanrasset , tome3,.

- **Roger duvollet ,**
1987, villages Algérie et oasis du Sahara , tome 7.

- **Seltzer (P),**
1946, Le Climat de l'Algérie , la typo litho,Alger.

- **Trumlet (C),**
1863, Les Français dans le désert , aux limites du Sahara algérien, Garnier Frères , librairies éditeurs ,Paris.

- **Trumlet (C) ,**
1892, l'Algérie légendaire , en pèlerinage ça et la aux tombeaux , principaux thaumaturges de l'islam (tell et Sahara) , Alger .

- **Vialatte (Jean) De Penille ,**
1949, Bousemghoun " Ksar berbère des monts des ksour et son oasis.

- 1994 ,**Plan directeur d'aménagement et d'urbanisme de la commune de bousemghoun** , rapport d'orientations et règlement , bureau d'études pluridisciplinaires , B.E.P cité Nasr , Elbayadh.

- **André (B),**
1936, Situation actuelle de parlars berbères dans le département d'Oran, Revue africaine, N° 368,369,pp1001...1006.

- **Arnaud (L),**
1861 , Histoire de l'Ouali Sid-Ahmed Et-Tedjani (extraite du kounache) , Revue africaine ,N°5, pp 462...474.

- **Colomieu ,**
1863 , Voyage dans le Sahara algérien de Géryville à Ouargla , le tour du monde, pp 161...199.

- **Commandant Cauvet ,**
1923 , Les marabouts, petits monument funéraires et votifs du nord de l'Afrique, Revue africaine, N° 64, Paris, pp 274...329 et pp 488...522.

- **Demaeght (L),**
1893 , Document Arabe, texte arabe et traduction française d'une lettre écrite par Hasen 33^{eme} et dernier Bey d'Oran à Ali Caid de Melliana, Bulletin de la société de géographie et d'archéologie d'Oran , pp 149...152.

- **Iliou et G.Lefelver,**
1972 , Cinq stations de gravures rupestres de la région de Bou-Semghoun (monts des ksours), Lybika , tome 20, Alger, pp180...186.

- **Réné (Basset),**
Juillet 1885, Notes de lexicographie berbères , dialecte des kçours oranais et de Figuig, Journal Asiatique, Tome 6, pp 302...370.

- **Réné(Basset),**
1885, Dialectes du sud oranais et de Figuig dialecte de Boussemer'oun, bulletin de correspondance africaine, tome 3, imp. de l'association ouvrières, Fontana et C^{ie} , Alger, pp389...427.

- **Trumelet (c),**
1888, L'histoire de l'insurrection dans le sud de la province d'Alger, Revue africaine, N°_146 .

6 - 1	مقدمة
	(الفصل الأول (دراسة)	
7	-I :
16 - 8	- II :
9.- 8 :	1
.10- 9	2
.12- 11 :	3
.13- 12 :	4
.16- 13	5
14	-
15	-
16	-
.24- 17	III -اللمحة التاريخية
17	-1
.24- 18	-2
.24- 21	-
.26- 25	-IV
25	1
25	2
26 ()	3
26	4
.9- 8	5
26	6
26	7

()

.34- 27	-I
.29	-1
30	-2
31	-3
32	-4
32	-5
34 - 33	-6
.42 - 35 ()	-II

()

.56 43	-I
.51 - 43	-
.44	-1
.45	-2
.46 - 45 ()	-3
.46	-4
.47	-5
.47	-6
.48	-7
.48	-8
.49	-9
.51	-10
.51 - 50	-11
56. - 51	-
.52 (1)	-1
.54 - 53 (2)	-2
.54 (3)	-3
.55 (4)	-4
.56 (5)	-5

.62 - 57	:	-II
.58 - 57	.	-1
.59 - 58	.	2
.61 - 60	.	3
.60	.	-
.61	.	-
61.	.	-
.62	.	4
(.)		
.67 - 63		-I
.64- 63	.	-1
.63	.	-
.64	.()	-
.65	.	-2
.66	.()	-3
.67	.	-4
82- 68		-II
.75- 68	.	-
.69 - 68		1
.71 - 69	.	2
70 - .69	.	-
.71 - 70	.	-
.71	.	-
.72	.	3
.73	.	4
.74	.	5
.74	.	6
.75	.	7

.82 - 76	- II
.77	1
.78	2
.79	3
.80	4
82 - .81	5
82 - .81	-
.82	-
.84 - 83		
.165 - 85		
.99 - 85		-1
.112 -100		-2
.117 - 113		-3
.165- - 118		-4
194. - 166		
167- 166		-1
.168		-2
169		-3
.170		-4
. 172 - 171		-5
.173		-6
. 176- 174		-7
.178- 177		-8
189 - .179		
.193- 190		

